

EXAMPLE P/N: QJS-B3-1-CAM (THREE OUTLETS AND LESS, ARRANGED PERPENDICULAR TO BOOM)
 NOTE: NOTE: ALL DIMENSIONS ARE APPROXIMATE. FOR SINGLE HOSE SHANK VERSIONS USE "L" OR "R" IN THE PART NUMBER TO SPECIFY LEFT OR RIGHT-HANDED HOSE SHANK ORIENTATION, WITH THE SPLIT EYELET POINTING FORWARD. SPECIFY CHEMSAVER® STARTING WITH OUTLET CLOSEST TO BOOM.

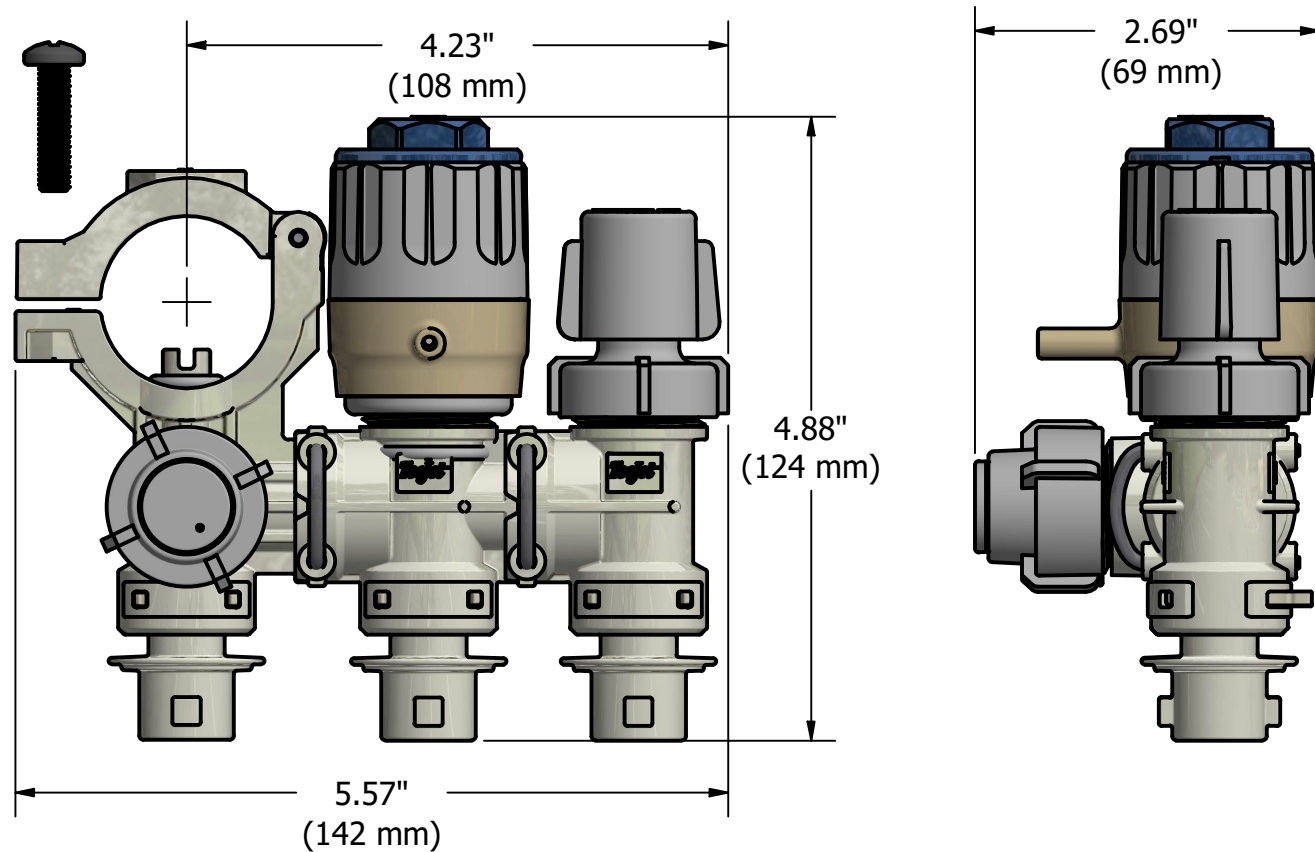

EXAMPLE PART #: QJS-B4-1-AAAA (FOUR OUTLETS, ARRANGED PARALLEL TO BOOM)

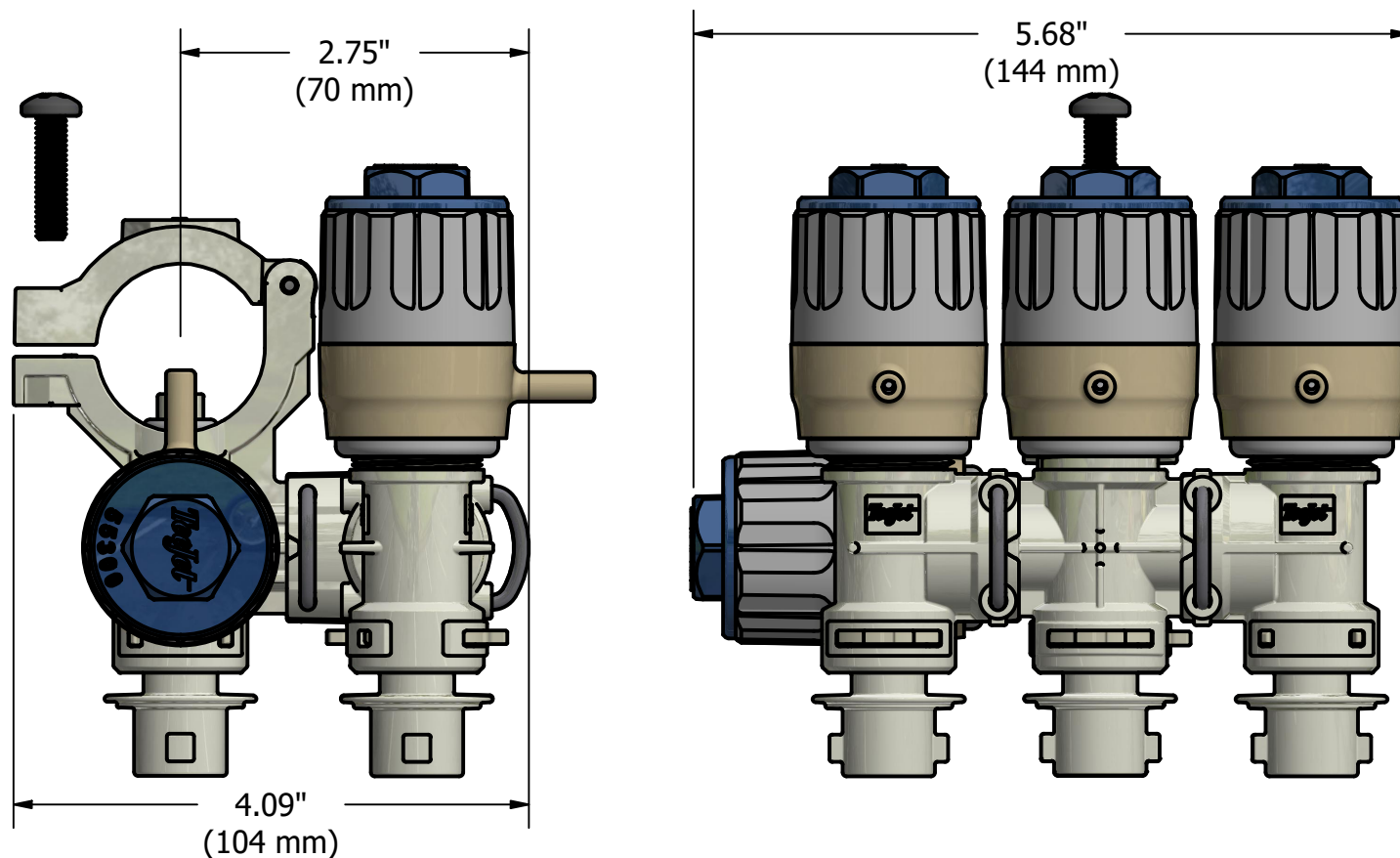

QJS- BOTTOM MOUNT STACKABLE NOZZLE BODY FOR WET AND DRY BOOMS

- * MULTIPLE OUTLET, UP TO THREE OUTLETS ON WHEN ARRANGED PERPENDICULAR TO BOOM; FOUR OUTLETS WHEN ARRANGED PARALLEL TO BOOM.
- * AVAILABLE IN WET AND DRY BOOM CONFIGURATIONS.
 NOTE: DRY BOOM ONLY AVAILABLE FOR THREE OR LESS OUTLET VERSIONS.
- * MADE OF CORROSION RESISTANT MATERIALS.
- * ATTACHES TO BOOM WITH M6-25mm STAINLESS STEEL PHILLIPS SCREW, AND M6x1mm NUT WHICH IS FIXED INTO LOWER BODY CLAMP.
- * STANDARD O-RINGS MADE OF VITON® .
- * MAXIMUM OPERATING PRESSURE 300 PSI (20.7 BAR).
- * MAXIMUM FLOW RATING 2.75 GPM (10.4 L/MIN) AT 5 PSI (0.34 BAR) PRESSURE DROP AND 4.0 GPM (15.1 L/MIN) AT 10 PSI (0.7 BAR) PRESSURE DROP PER OUTLET.
- * FEATURES QUICK TEEJET CAP CONNECTION.
- * CAN BE EQUIPPED WITH MOST TEEJET CHEMSAVER® OPTIONS.
 NOTE: FLOW RATES THROUGH DIFFERENT CHEMSAVER® OPTIONS CAN BE FOUND ON THEIR CORRESPONDING DATA SHEETS.
- * MATERIALS: WETTED PARTS ARE NYLON AND VITON® .
 NOTE: DIFFERENT CHEMSAVER OPTIONS INCLUDE EPDM, KYNAR®, NYLON AND VITON® .
- * WET BOOM SIZES: 20mm AND 25mm TUBING; 1/2", 3/4", AND 1" PIPE.
- * DRY BOOM HOSE BARB SIZES: 1/2", 3/4", AND 1" I.D. HOSE.
- * 8MM HEX SOCKET ON UPPER CLAMP STANDARD; 6MM AVAILABLE.
- * FOR "HOW TO ORDER" INSTRUCTIONS PLEASE SEE DATA SHEET DS58585.

INSTALLATION NOTE:

- * PLACE SCREW IN NUT AND BEGIN TURNING BY HAND (1-2 TURNS) TO ENSURE PROPER ENGAGEMENT BEFORE USING A LOW SPEED TORQUE GUN.
- * TORQUE TO 20-23 IN-LBS.

KYNAR® IS A REGISTERED TRADEMARK OF ARKEMA, INC.
 VITON® IS A REGISTERED TRADEMARK OF DUPONT PERFORMANCE ELASTOMERS, INC.

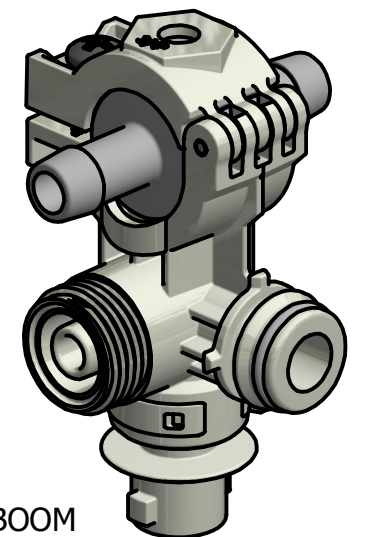

QJS DRY BOOM CONFIGURATION

DESCRIPTION:		 Spraying Systems Co.® Spray Nozzles and Accessories P.O. Box 7900 - Wheaton, IL 60189-7900	
QJS-B STACKABLE QUICK TEEJET® BOTTOM MOUNT NOZZLE BODY ASSEMBLY			
REVISION NO.	3	DATA SHEET	
REFERENCE:	10/14/14	DSQJS-B	
		SHEET:	1 OF 1
		DWG SIZE:	B