

FEATURES

- QUICK HAND INDEXING WITH THREE OUTLET TURRET.
- HINGED UPPER CLAMP AND SINGLE SCREW REDUCES ASSEMBLY TIME.
- ALLOWS FOR RAPID CHANGE OF SPRAY TIPS WITH USE OF QUICK TEEJET® CAPS.
- NOTCHED INLET TUBE PREVENTS SEDIMENT BUILDUP IN BOOM.
- MADE OF CORROSION RESISTANT MATERIALS.
- STANDARD O-RINGS AND DIAPHRAGM MADE OF VITON®
- STANDARD OPENING PRESSURE - 15 PSI (1.0 BAR)
- STANDARD CLOSING PRESSURE - 10 PSI (0.7 BAR)
- MAXIMUM OPERATING PRESSURE - 150 PSI (10 BAR)
- FLOW RATES: 3 GPM (11.4 l/min) WITH A 5 PSI (.34 BAR) DROP THROUGH TURRET.
- HEX SOCKET IN CENTER OF UPPER CLAMP PERMITS ATTACHMENT OF BODY TO FLAT SURFACE USING CUSTOMER SUPPLIED FASTENER. 5/16" OR M8 BOLT.
- AVAILABLE FOR 3/4" OR 1" PIPE SIZE
- STANDARD O-RING P/N: CP7717-2/110-VI REQUIRES 3/8" (9.5mm) HOLE DRILLED IN PIPE.
- OPTIONAL ADAPTER GASKET P/N: CP98488-VI REQUIRES 11/16" (17.5mm) HOLE DRILLED IN PIPE.

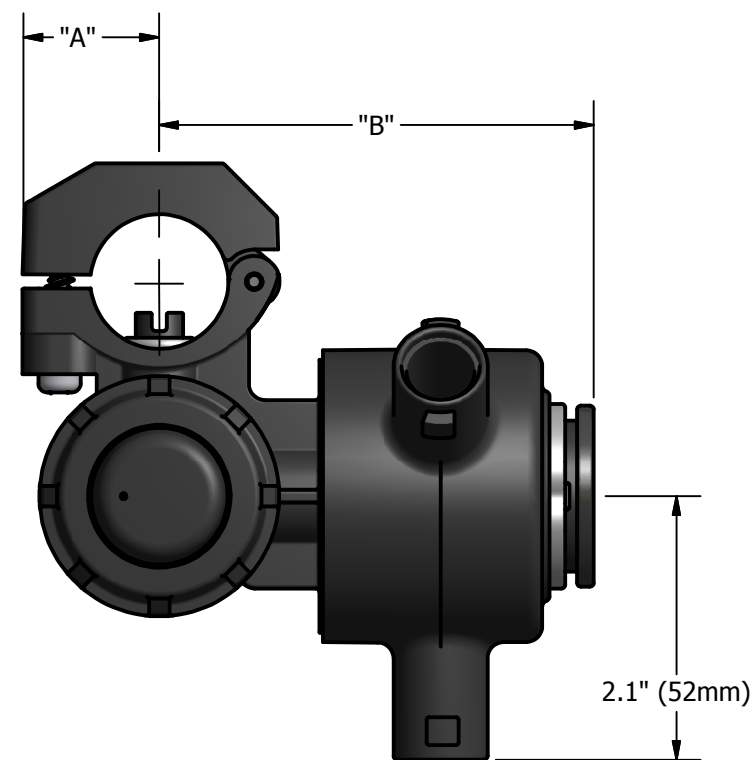
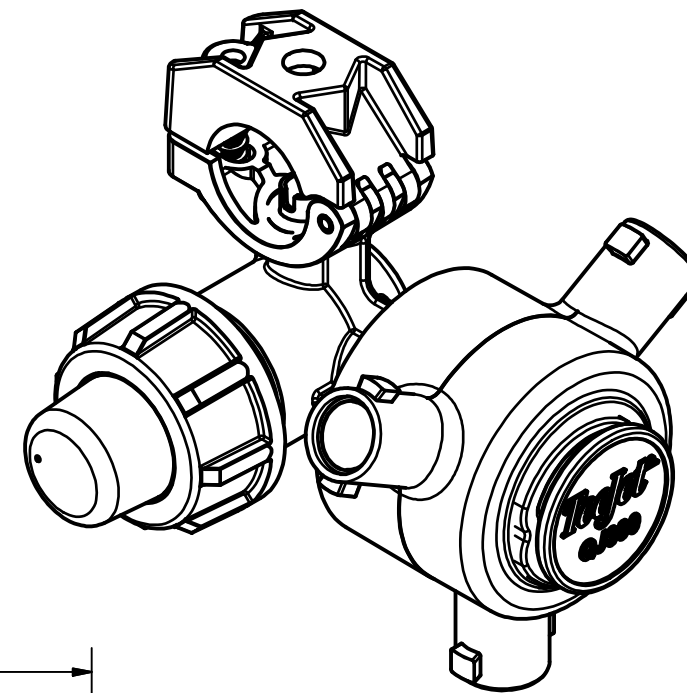

TO INSTALL STANDARD ASSEMBLY DRILL 3/8" (9.5mm) DIAMETER HOLE IN PIPE, DEBURR, THEN INSERT NOZZLE BODY INLET AND CLAMP ASSEMBLY IN PLACE.

TO INSTALL ASSEMBLY WITH 11/16" ADAPTER GASKET DRILL 11/16" (17.5mm) DIAMETER HOLE IN PIPE, DEBURR, THEN INSERT NOZZLE BODY INLET AND CLAMP ASSEMBLY IN PLACE.

HOW TO ORDER

ORDER WITH STANDARD VITON O-RING

- QJ383F-1-NYB - 1" NOZZLE BODY
- QJ383F-3/4-NYB - 3/4" NOZZLE BODY

ORDER WITH 11/16 ADAPTER GASKET

- QJ383F-1x11/16-NYB - 1" NOZZLE BODY w/ 11/16" GASKET
- QJ383F-3/4x11/16-NYB - 3/4" NOZZLE BODY w/ 11/16" GASKET

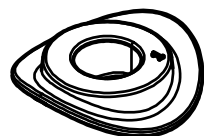

PART NO.	TO CLAMP ON	"A"	"B"
QJ383-3/4-NYB or QJ383-3/4x11/16-NYB	3/4" PIPE	1.05" 26.5mm	3.35" 85mm
QJ383-1-NYB or QJ383-1-11/16-NYB	1" PIPE	1.15" 29.2mm	3.35" 85mm

DESCRIPTION:

QJ380 WET BOOM
HIGH FLOW
DIAPHRAGM CHECK VALVE
NOZZLE BODY ASSEMBLY

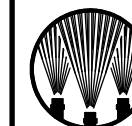

Spraying Systems Co.®
Spray Nozzles and Accessories
P.O. Box 7900 - Wheaton, IL 60189-7900

REVISION NO.

DATA SHEET

REFERENCE:

DSQJ380-WB

SHEET: 1 OF 1

DWG SIZE: B