

Turbo TeeJet® Induction

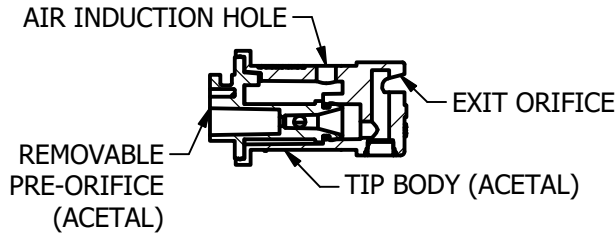

TTI110_-VP SPRAY TIP
(CROSS SECTION VIEW)

FEATURES:

- TAPERED EDGE WIDE ANGLE FLAT SPRAY PATTERN FOR UNIFORM COVERAGE IN BROADCAST SPRAYING.
- LARGE, ROUND FREE PASSAGE TO MINIMIZE CLOGGING.
- LARGER DROPLETS ARE PRODUCED THROUGH THE USE OF A VENTURI AIR ASPIRATOR, RESULTING IN LESS DRIFT.
- SUGGESTED SPRAY PRESSURE RANGE: 1.0-7.0 bar.
- ALL ACETAL CONSTRUCTION FOR EXCELLENT CHEMICAL RESISTANCE TO CORROSIVE SOLUTIONS.
- SUPERIOR WEAR CHARACTERISTICS.
- AUTOMATIC SPRAY ALIGNMENT WITH 25598_-NYR QUICK TEEJET CAP AND GASKET FOR CAPACITIES 015 THRU 06; 114502_-CELR FOR CAPACITIES 08 & 10.
- CAN ALSO BE USED WITH 11443A-*_-CELR CAP AND GASKET.

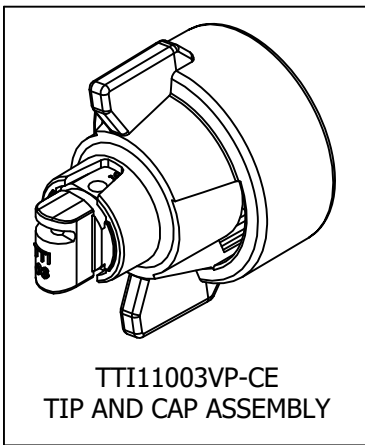

TTI11003VP-CE
TIP AND CAP ASSEMBLY

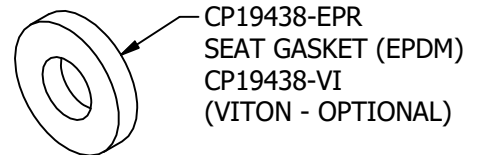

CP19438-EPR
SEAT GASKET (EPDM)
CP19438-VI
(VITON - OPTIONAL)

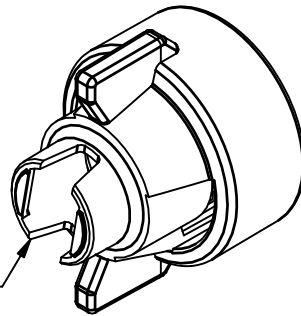

CP115834A-*_-CE
QUICK TEEJET CAP (CELCON)
FOR 015 THRU 06 CAPACITIES

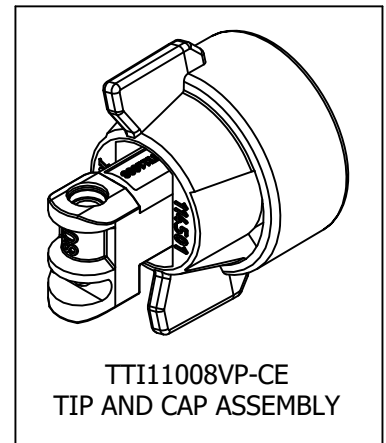

TTI11008VP-CE
TIP AND CAP ASSEMBLY

CP114501A-*_-CE
QUICK TEEJET CAP (CELCON)
FOR 08 & 10 CAPACITIES

DROPLET SIZE CATEGORIES			
C	VC	XC	UC
COARSE	VERY COARSE	EXTREMELY COARSE	ULTRA COARSE

OPTIMUM SPRAY HEIGHT	
50 cm SPACING	75 cm SPACING
50 cm	75 cm

DROPLET SIZE CLASSIFICATIONS ARE BASED ON BCPC SPECIFICATIONS AND IN ACCORDANCE WITH ISO 25358 AT THE DATE OF PRINTING. CLASSIFICATIONS ARE SUBJECT TO CHANGE.

DESCRIPTION:

LITERS PER HECTARE
TABULATION FOR
TTI110_-VP
TURBO TEEJET® AIR INDUCTION
POLYMER FLAT SPRAY TIP
(METRIC)



REVISION NO.	6	DATASHEET	
REFERENCE:	12/20/19	DS56525M	
SHEET:	1 OF 3	DWG SIZE:	A

TIP COLOR VISIFLO	TIP No. STRAINER MESH SIZE	LIQUID PRESSURE (bar)	DROPLET SIZE	CAPACITY ONE NOZZLE (l/min)	LITERS PER HECTARE 50 cm NOZZLE SPACING														
					4 km/h	5 km/h	6 km/h	7 km/h	8 km/h	10 km/h	12 km/h	14 km/h	16 km/h	18 km/h	20 km/h	25 km/h	30 km/h	35 km/h	
GREEN	110015-VP (100 MESH)	1.0	UC	0.34	102	81.6	68.0	58.3	51.0	45.2	34.0	29.1	25.5	22.7	20.4	16.3	13.6	11.7	
		1.5	UC	0.42	126	101	84.0	72.0	63.0	50.4	42.0	36.0	31.5	28.0	25.2	20.2	16.8	14.4	
		2.0	UC	0.48	144	115	96.0	82.3	72.0	57.6	48.8	41.1	36.0	32.0	28.8	23.0	19.2	16.5	
		2.5	UC	0.54	162	130	108	92.6	81.0	64.8	54.0	46.3	40.5	36.0	32.4	25.9	21.6	18.5	
		3.0	XC	0.59	177	142	118	101	88.5	70.8	59.0	50.6	41.3	39.3	35.4	28.3	23.6	20.2	
		4.0	XC	0.68	204	163	136	117	102	81.6	68.0	58.3	51.0	45.3	40.8	32.6	27.2	23.3	
		5.0	VC	0.76	228	182	152	130	114	91.2	76.0	65.1	57.0	50.7	45.6	36.5	30.4	26.1	
		7.0	VC	0.83	249	199	166	142	125	99.8	83.0	71.1	62.3	55.3	49.8	39.8	33.2	28.5	
YELLOW	11002-VP (50 MESH)	1.0	UC	0.46	138	110	92.0	78.9	69.0	55.2	46.0	39.4	34.5	30.7	27.6	22.1	18.4	15.8	
		1.5	UC	0.56	168	134	112	96.0	84.0	67.2	56.0	48.0	42.0	37.3	33.6	26.9	22.4	19.2	
		2.0	UC	0.65	195	156	130	111	97.5	78.0	65.0	55.7	48.8	43.3	39.0	31.2	26.0	22.3	
		2.5	UC	0.72	216	173	144	123	108	86.4	72.0	61.7	54.0	48.0	43.2	34.6	28.8	24.7	
		3.0	XC	0.79	237	188	158	135	118	94.8	79.0	67.7	59.3	52.7	47.4	37.9	31.6	27.1	
		4.0	XC	0.91	273	218	182	156	137	109	91.0	78.0	68.3	60.7	54.6	43.7	36.4	31.2	
		5.0	VC	1.02	306	246	204	175	153	122	102	87.4	76.5	68.0	61.2	49.0	40.8	36.0	
		7.0	VC	1.12	336	268	224	192	168	134	112	96.0	84.0	74.7	67.2	53.8	44.8	38.4	
VIOLET	110025-VP (50 MESH)	1.0	UC	0.57	171	137	114	97.7	85.5	68.4	57.0	48.9	42.8	38.0	34.2	27.4	22.8	19.5	
		1.5	UC	0.70	210	168	140	120	105	84.0	70.0	60.0	52.5	46.7	42.0	33.6	28.0	24.0	
		2.0	UC	0.81	243	194	162	139	122	97.2	81.0	69.4	60.8	54.0	48.6	38.9	32.4	27.8	
		2.5	UC	0.90	270	216	180	154	135	108	90.0	77.1	67.5	60.0	54.0	43.2	36.0	30.9	
		3.0	XC	0.99	297	238	198	170	149	119	99.0	84.9	74.3	66.0	59.4	47.5	39.6	33.9	
		4.0	XC	1.14	342	274	228	195	171	137	114	97.7	85.5	76.0	68.4	54.7	45.6	39.1	
		5.0	VC	1.28	384	307	256	219	192	154	128	110	96.0	85.3	76.8	61.4	51.2	43.9	
		7.0	VC	1.40	420	336	280	240	210	168	140	120	105	93.3	84.0	67.2	56.0	48.0	
BLUE	11003-VP (50 MESH)	1.0	UC	0.68	204	163	138	117	102	81.6	68.0	58.3	51.0	45.3	40.8	32.6	27.2	23.3	
		1.5	UC	0.83	240	188	166	142	125	99.8	83.0	71.1	62.3	55.3	49.8	39.8	33.2	28.5	
		2.0	UC	0.96	288	230	192	165	144	115	96.0	82.3	72.0	64.0	57.6	46.1	38.4	32.9	
		2.5	UC	1.08	324	259	216	185	162	130	108	92.6	81.0	72.0	64.8	51.8	43.2	37.0	
		3.0	XC	1.18	354	283	236	202	177	142	118	101	88.5	78.7	70.8	56.6	47.2	40.5	
		4.0	XC	1.36	408	326	272	233	204	163	136	117	102	90.7	81.6	65.3	54.4	46.6	
		5.0	VC	1.52	456	365	304	261	228	182	152	130	114	101	91.2	73.0	60.8	52.1	
		7.0	VC	1.67	501	401	334	286	251	208	167	143	125	111	100	80.2	66.8	57.3	
RED	11004-VP (50 MESH)	1.0	UC	0.91	273	218	182	156	137	109	91.0	78.0	68.3	60.7	54.6	43.7	36.4	31.2	
		1.5	UC	1.12	336	268	224	192	168	134	112	96.0	84.0	74.7	67.2	53.8	44.8	38.4	
		2.0	UC	1.29	387	310	258	221	194	155	129	111	96.8	86.8	77.4	61.9	51.6	44.2	
		2.5	UC	1.44	432	346	288	247	216	173	144	123	108	96.0	86.4	69.1	57.6	49.4	
		3.0	XC	1.58	474	379	316	271	237	198	158	135	119	105	94.8	75.8	63.2	54.2	
		4.0	XC	1.82	546	437	364	312	273	218	182	156	137	121	109	87.4	72.8	62.4	
		5.0	VC	2.04	612	490	408	350	306	245	204	175	153	136	122	97.9	81.6	69.9	
		7.0	VC	2.23	668	535	446	382	335	268	223	191	167	149	134	107	89.2	76.5	
BROWN	11005-VP (50 MESH)	1.0	UC	1.14	342	274	228	195	171	137	114	97.7	85.5	76.0	68.4	54.7	45.6	39.1	
		1.5	UC	1.39	417	334	276	238	209	167	139	119	104	92.7	83.4	66.7	55.6	47.7	
		2.0	UC	1.61	483	386	322	276	242	193	161	138	121	107	96.6	77.3	64.4	55.2	
		2.5	UC	1.80	540	432	360	309	270	216	180	154	135	120	108	86.4	72.0	61.7	
		3.0	XC	1.97	591	473	394	336	296	236	197	169	146	131	116	94.6	78.8	67.5	
		4.0	XC	2.27	681	545	454	389	341	272	227	195	170	151	136	109	90.8	77.8	
		5.0	VC	2.54	762	610	509	436	381	305	254	218	191	169	152	122	102	87.1	
		7.0	VC	2.79	837	670	558	478	419	335	279	230	209	186	167	134	112	95.7	
GRAY	11006-VP (50 MESH)	1.0	UC	1.37	411	329	274	235	206	164	137	117	103	91.3	82.2	65.8	54.8	47.0	
		1.5	UC	1.68	504	403	336	288	252	202	168	144	126	112	101	80.6	67.2	57.6	
		2.0	UC	1.94	582	466	388	333	291	239	194	166	146	129	116	93.1	77.6	66.5	
		2.5	UC	2.16	648	518	432	370	324	259	216	185	162	144	130	104	86.4	74.1	
		3.0	XC	2.37	711	569	474	406	356	284	237	203	178	158	142	114	94.8	81.3	
		4.0	XC	2.74	822	658	548	470	411	329	274	235	206	183	164	132	110	93.9	
		5.0	VC	3.06	918	734	612	525	458	367	306	262	230	204	184	147	122	105	
		7.0	VC	3.52	1086	869	724	621	543	434	362	310	272	241	217	174	145	124	

DESCRIPTION:
 LITERS PER HECTARE
 TABULATION FOR
 TT1110_-VP
 TURBO TEEJET® AIR INDUCTION
 POLYMER FLAT SPRAY TIP
 (METRIC)



REVISION NO.	6	DATASHEET	
REFERENCE:	12/20/19	DS56525M	
	SHEET:	2 OF 3	DWG SIZE: A

TIP COLOR VISIFLO	TIP No. STRAINER MESH SIZE	LIQUID PRESSURE (bar)	DROPLET SIZE	CAPACITY ONE NOZZLE (l/min)	LITERS PER HECTARE 50 cm NOZZLE SPACING															
					4 km/h	5 km/h	6 km/h	7 km/h	8 km/h	10 km/h	12 km/h	14 km/h	16 km/h	18 km/h	20 km/h	25 km/h	30 km/h	35 km/h		
WHITE	11008-VP	1.0	UC	1.82	546	437	364	312	273	218	182	158	137	121	109	87.4	72.8	62.4		
		1.5	UC	2.23	669	535	446	382	335	268	223	191	167	149	134	107	89.2	76.5		
		2.0	UC	2.58	774	619	516	442	387	310	258	221	194	172	155	124	103	88.5		
		2.5	UC	2.88	864	691	576	494	432	345	288	247	216	192	173	138	115	98.7		
		3.0	XC	3.16	948	758	632	542	474	379	316	271	237	211	190	152	126	108		
		4.0	XC	3.65	1095	876	730	626	548	488	385	313	274	243	219	175	146	125		
		5.0	VC	4.08	1224	979	816	688	612	490	408	350	306	272	245	196	163	140		
		6.0	VC	4.47	1341	1073	894	766	671	536	447	383	335	298	268	215	179	153		
		7.0	C	4.83	1449	1159	966	828	725	580	483	414	362	322	260	232	193	166		
LIGHT BLUE	11010-VP	1.0	UC	2.28	684	547	456	391	342	274	228	195	171	152	137	109	91.2	78.2		
		1.5	UC	2.79	837	670	558	478	419	335	279	239	209	186	167	134	112	95.7		
		2.0	UC	3.23	969	775	646	554	485	388	323	277	242	215	194	155	129	111		
		2.5	UC	3.61	1083	866	722	619	542	433	361	309	271	241	217	173	144	124		
		3.0	XC	3.95	1185	948	790	677	593	474	395	339	296	263	237	190	158	135		
		4.0	XC	4.56	1368	1094	912	782	684	547	456	391	342	304	274	219	182	156		
		5.0	VC	5.10	1530	1224	1020	874	765	612	510	437	383	340	306	245	204	175		
		6.0	VC	5.59	1677	1342	1118	958	839	671	559	479	419	373	335	268	224	192		
		7.0	C	6.03	1809	1447	1206	1034	905	724	603	517	452	402	362	289	241	207		

DESCRIPTION:

LITERS PER HECTARE
TABULATION FOR
TT1110__VP
TURBO TEEJET® AIR INDUCTION
POLYMER FLAT SPRAY TIP
(METRIC)



REVISION NO. 6

REFERENCE: 12/20/19

DATASHEET
DS56525M

SHEET: 3 OF 3 DWG SIZE: A