

Turbo TeeJet® Induction

TTI11003-VP SPRAY TIP (CROSS SECTION VIEW)

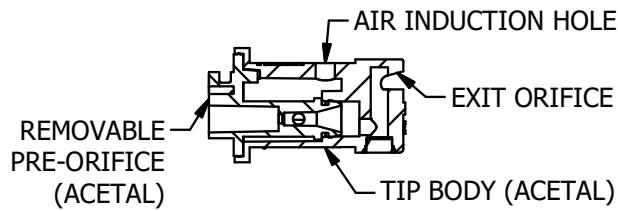

FEATURES:

- TAPERED EDGE WIDE ANGLE FLAT SPRAY PATTERN FOR UNIFORM COVERAGE IN BROADCAST SPRAYING.
- LARGE, ROUND FREE PASSAGE TO MINIMIZE CLOGGING.
- LARGER DROPLETS ARE PRODUCED THROUGH THE USE OF A VENTURI AIR ASPIRATOR, RESULTING IN LESS DRIFT.
- SUGGESTED SPRAY PRESSURE RANGE: 15-100 PSI.
- ALL ACETAL CONSTRUCTION FOR EXCELLENT CHEMICAL RESISTANCE TO CORROSIVE SOLUTIONS.
- SUPERIOR WEAR CHARACTERISTICS.
- AUTOMATIC SPRAY ALIGNMENT WITH 115835A-_-CELR QUICK TEEJET® CAP AND GASKET FOR CAPACITIES 01 THRU 06; 114502A-_-CELR FOR CAPACITIES 08 & 10.
- CAN ALSO BE USED WITH 114443A-*_-CELR CAP AND GASKET.

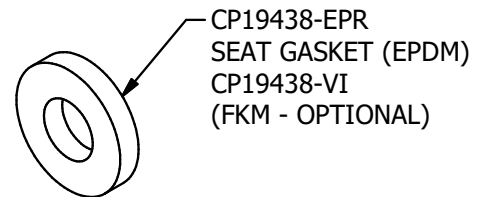
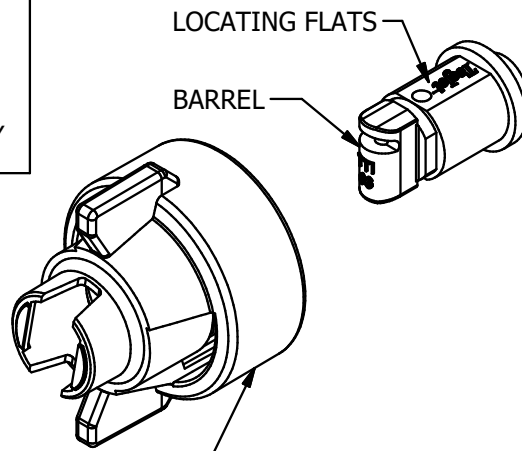
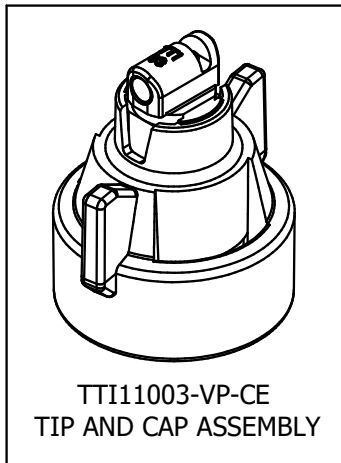

CP115834A-*_-CE
QUICK TEEJET® CAP (CELCON)
CP114501A-*_-CE
QUICK TEEJET® CAP (CELCON)
FOR 08 & 10 CAPACITIES

* SPECIFY COLOR CODE

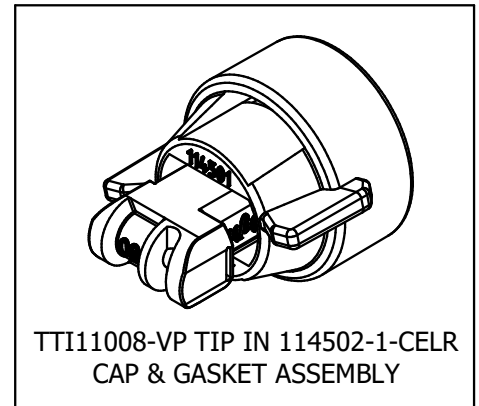

DROPLET SIZE CATEGORIES			
UC	XC	VC	C
ULTRA COARSE	EXTREMELY COARSE	VERY COARSE	COARSE

OPTIMUM SPRAY HEIGHT	
20" SPACING	30" SPACING
20"	30"

DROPLET SIZE CLASSIFICATIONS ARE BASED ON BCPC SPECIFICATIONS AND IN ACCORDANCE WITH ISO 25358 AT THE DATE OF PRINTING. CLASSIFICATIONS ARE SUBJECT TO CHANGE.

DESCRIPTION:

GALLONS PER ACRE
TABULATION FOR
TTI110 _-VP
TURBO TEEJET® AIR INDUCTION
POLYMER FLAT SPRAY TIP



REVISION NO.	DATASHEET	
REFERENCE:	DS56525	
11/20/19	SHEET: 1 OF 3	DWG SIZE: A

TIP COLOR VISIFLO	TIP No. STRAINER MESH SIZE	LIQUID PRESSURE (PSI)	DROPLET SIZE	CAPACITY ONE NOZZLE (GPM)	CAPACITY ONE NOZZLE (oz./min)	GALLONS PER ACRE 20" NOZZLE SPACING								GALLONS PER 1000 Sq. Ft. 20" NOZZLE SPACING			
						4 MPH	5 MPH	6 MPH	8 MPH	10 MPH	12 MPH	15 MPH	20 MPH	2 MPH	3 MPH	4 MPH	5 MPH
ORANGE	11001-VP (100 MESH)	15	UC	0.061	7.8	4.5	3.6	3.0	2.3	1.8	1.5	1.2	0.91	0.21	0.14	0.10	0.08
		20	UC	0.071	9.1	5.3	4.2	3.5	2.6	2.1	1.8	1.4	1.1	0.24	0.16	0.12	0.10
		30	UC	0.087	11	6.5	5.2	4.3	3.2	2.6	2.2	1.7	1.3	0.30	0.20	0.15	0.12
		40	XC	0.10	13	7.4	5.9	5.0	3.7	3.0	2.5	2.0	1.5	0.34	0.23	0.17	0.14
		50	XC	0.11	14	8.2	6.5	5.4	4.1	3.3	2.7	2.2	1.6	0.38	0.25	0.19	0.15
		60	XC	0.12	15	8.9	7.1	5.9	4.5	3.6	3.0	2.4	1.8	0.41	0.27	0.20	0.16
		70	VC	0.13	17	9.7	7.7	6.4	4.8	3.9	3.2	2.6	1.9	0.44	0.30	0.22	0.18
		80	VC	0.14	18	10.4	8.3	6.9	5.2	4.2	3.5	2.8	2.1	0.48	0.32	0.24	0.19
		90	VC	0.15	19	11.1	8.9	7.4	5.6	4.5	3.7	3.0	2.2	0.51	0.34	0.26	0.20
		100	VC	0.16	20	11.9	9.5	7.9	5.9	4.8	4.0	3.2	2.4	0.55	0.36	0.27	0.22
GREEN	110015-VP (100 MESH)	15	UC	0.092	12	6.8	5.5	4.6	3.4	2.7	2.3	1.8	1.4	0.31	0.21	0.16	0.13
		20	UC	0.11	14	8.2	6.5	5.4	4.1	3.3	2.7	2.2	1.6	0.37	0.25	0.19	0.15
		30	UC	0.13	17	9.7	7.7	6.4	4.8	3.9	3.2	2.6	1.9	0.44	0.29	0.22	0.18
		40	XC	0.15	19	11.1	8.9	7.4	5.6	4.5	3.7	3.0	2.2	0.51	0.34	0.26	0.20
		50	XC	0.17	22	12.6	10.1	8.4	6.3	5.0	4.2	3.4	2.5	0.58	0.39	0.29	0.23
		60	XC	0.18	23	13.4	10.7	8.9	6.7	5.3	4.5	3.6	2.7	0.61	0.41	0.31	0.24
		70	VC	0.20	26	14.9	11.9	9.9	7.4	5.9	5.0	4.0	3.0	0.68	0.45	0.34	0.27
		80	VC	0.21	27	15.6	12.5	10.4	7.8	6.2	5.2	4.2	3.1	0.71	0.48	0.36	0.29
		90	VC	0.23	29	17.1	13.7	11.4	8.5	6.8	5.7	4.6	3.4	0.78	0.52	0.39	0.31
		100	VC	0.24	31	17.8	14.3	11.9	8.9	7.1	5.9	4.8	3.6	0.82	0.54	0.41	0.33
YELLOW	11002-VP (50 MESH)	15	UC	0.12	15	8.9	7.1	5.9	4.5	3.6	3.0	2.4	1.8	0.41	0.27	0.20	0.16
		20	UC	0.14	18	10.4	8.3	6.9	5.2	4.2	3.5	2.8	2.1	0.48	0.32	0.24	0.19
		30	UC	0.17	22	12.6	10.1	8.4	6.3	5.0	4.2	3.4	2.5	0.58	0.39	0.29	0.23
		40	XC	0.20	26	14.9	11.9	9.9	7.4	5.9	5.0	4.0	3.0	0.68	0.45	0.34	0.27
		50	XC	0.22	28	16.3	13.1	10.9	8.2	6.5	5.4	4.4	3.3	0.75	0.50	0.37	0.30
		60	XC	0.24	31	17.8	14.3	11.9	8.9	7.1	5.9	4.8	3.6	0.82	0.54	0.41	0.33
		70	VC	0.26	33	19.3	15.4	12.9	9.7	7.7	6.4	5.1	3.9	0.88	0.59	0.44	0.35
		80	VC	0.28	36	21	16.6	13.9	10.4	8.3	6.9	5.5	4.2	0.95	0.63	0.48	0.38
		90	VC	0.30	38	22	17.8	14.9	11.1	8.9	7.4	5.9	4.5	1.0	0.68	0.51	0.41
		100	VC	0.32	41	24	19.0	15.8	11.9	9.5	7.9	6.3	4.8	1.1	0.73	0.54	0.44
VIOLET	110025-VP (50 MESH)	15	UC	0.15	19	11.1	8.9	7.4	5.6	4.5	3.7	3.0	2.2	0.51	0.34	0.26	0.20
		20	UC	0.18	23	13.4	10.7	8.9	6.7	5.3	4.5	3.6	2.7	0.61	0.41	0.31	0.24
		30	UC	0.22	28	16.3	13.1	10.9	8.2	6.5	5.4	4.4	3.3	0.75	0.50	0.37	0.30
		40	XC	0.25	32	18.6	14.9	12.4	9.3	7.4	6.2	5.0	3.7	0.85	0.57	0.43	0.34
		50	XC	0.28	36	21	16.6	13.9	10.4	8.3	6.9	5.5	4.2	0.95	0.63	0.48	0.38
		60	XC	0.31	40	23	18.4	15.3	11.5	9.2	7.7	6.1	4.6	1.1	0.70	0.53	0.42
		70	VC	0.33	42	25	19.6	16.3	12.3	9.8	8.2	6.5	4.9	1.1	0.75	0.56	0.45
		80	VC	0.35	45	26	21	17.3	13.0	10.4	8.7	6.9	5.2	1.2	0.79	0.60	0.48
		90	VC	0.38	49	28	23	18.8	14.1	11.3	9.4	7.5	5.6	1.3	0.86	0.65	0.52
		100	VC	0.40	51	30	24	19.8	14.9	11.9	9.9	7.9	5.9	1.4	0.91	0.68	0.54
BLUE	11003-VP (50 MESH)	15	UC	0.18	23	13.4	10.7	8.9	6.7	5.3	4.5	3.6	2.7	0.61	0.41	0.31	0.24
		20	UC	0.21	27	15.6	12.5	10.4	7.8	6.2	5.2	4.2	3.1	0.71	0.48	0.36	0.29
		30	UC	0.26	33	19.3	15.4	12.9	9.7	7.7	6.4	5.1	3.9	0.88	0.59	0.44	0.35
		40	XC	0.30	38	22	17.8	14.9	11.1	8.9	7.4	5.9	4.5	1.0	0.68	0.51	0.41
		50	XC	0.34	44	25	20	16.8	12.6	10.1	8.4	6.7	5.0	1.2	0.77	0.58	0.46
		60	XC	0.37	47	27	22	18.3	13.7	11.0	9.2	7.3	5.5	1.3	0.84	0.63	0.50
		70	VC	0.40	51	30	24	19.8	14.9	11.9	9.9	7.9	5.9	1.4	0.91	0.68	0.54
		80	VC	0.42	54	31	25	21	15.6	12.5	10.4	8.3	6.2	1.4	0.95	0.71	0.57
		90	VC	0.45	58	33	27	22	16.7	13.4	11.1	8.9	6.7	1.5	1.0	0.77	0.61
		100	VC	0.47	60	35	28	23	17.4	14	11.6	9.3	7	1.6	1.1	0.80	0.64
RED	11004-VP (50 MESH)	15	UC	0.24	31	17.8	14.3	11.9	8.9	7.1	5.9	4.8	3.6	0.82	0.54	0.41	0.33
		20	UC	0.28	36	21	16.6	13.9	10.4	8.3	6.9	5.5	4.2	0.95	0.63	0.48	0.38
		30	UC	0.35	45	26	21	17.3	13.0	10.4	8.7	6.9	5.2	1.2	0.79	0.60	0.48
		40	XC	0.40	51	30	24	19.8	14.9	11.9	9.9	7.9	5.9	1.4	0.91	0.68	0.54
		50	XC	0.45	58	33	27	22	16.7	13.4	11.1	8.9	6.7	1.5	1.0	0.77	0.61
		60	XC	0.49	63	36	29	24	18.2	14.6	12.1	9.7	7.3	1.7	1.1	0.83	0.67
		70	VC	0.53	68	39	31	26	19.7	15.7	13.1	10.5	7.9	1.8	1.2	0.90	0.72
		80	VC	0.57	73	42	34	28	21	16.9	14.1	11.3	8.5	1.9	1.3	0.97	0.78
		90	VC	0.60	77	45	36	30	22	17.8	14.9	11.9	8.9	2.0	1.4	1.0	0.82
		100	VC	0.63	81	47	37	31	23	18.7	15.6	12.5	9.4	2.1	1.4	1.1	0.86

DESCRIPTION: GALLONS PER ACRE TABULATION FOR TTI110 _-VP TURBO TEEJET® AIR INDUCTION POLYMER FLAT SPRAY TIP		
	REVISION NO.	DATASHEET DS56525
	REFERENCE: 11/20/19	SHEET: 2 OF 3 DWG SIZE: A

TIP COLOR VISIFLO	TIP No. STRAINER MESH SIZE	LIQUID PRESSURE (PSI)	DROPLET SIZE	CAPACITY ONE NOZZLE (GPM)	CAPACITY ONE NOZZLE (oz./min)	GALLONS PER ACRE 20" NOZZLE SPACING								GALLONS PER 1000 Sq. Ft. 20" NOZZLE SPACING			
						4 MPH	5 MPH	6 MPH	8 MPH	10 MPH	12 MPH	15 MPH	20 MPH	2 MPH	3 MPH	4 MPH	5 MPH
BROWN	11005-VP (50 MESH)	15	UC	0.31	40	23	18.4	15.3	11.5	9.2	7.7	6.1	4.6	1.1	0.70	0.53	0.42
		20	UC	0.35	45	26	21	17.3	13.0	10.4	8.7	6.9	5.2	1.2	0.79	0.60	0.48
		30	UC	0.43	55	32	26	21	16.0	12.8	10.6	8.5	6.4	1.5	0.97	0.73	0.58
		40	XC	0.50	64	37	30	25	18.6	14.9	12.4	9.9	7.4	1.7	1.1	0.85	0.68
		50	XC	0.56	72	42	33	28	21	16.6	13.9	11.1	8.3	1.9	1.3	0.95	0.76
		60	XC	0.61	78	45	36	30	23	18.1	15.1	12.1	9.1	2.1	1.4	1.0	0.83
		70	VC	0.66	84	49	39	33	25	19.6	16.3	13.1	9.8	2.2	1.5	1.1	0.90
		80	VC	0.71	91	53	42	35	26	21	17.6	14.1	10.5	2.4	1.6	1.2	0.97
		90	VC	0.75	96	56	45	37	28	22	18.6	14.9	11.1	2.6	1.7	1.3	1.0
		100	VC	0.79	101	59	47	39	29	23	19.6	15.6	11.7	2.7	1.8	1.3	1.1
GRAY	11006-VP (50 MESH)	15	UC	0.37	47	27	22	18.3	13.7	11.0	9.2	7.3	5.5	1.3	0.84	0.63	0.50
		20	UC	0.42	54	31	25	21	15.6	12.5	10.4	8.3	6.2	1.4	0.95	0.71	0.57
		30	UC	0.52	67	39	31	26	19.3	15.4	12.9	10.3	7.7	1.8	1.2	0.88	0.71
		40	XC	0.60	77	45	36	30	22	17.8	14.9	11.9	8.9	2.0	1.4	1.0	0.82
		50	XC	0.67	86	50	40	33	25	19.9	16.6	13.3	9.9	2.3	1.5	1.1	0.91
		60	VC	0.73	93	54	43	36	27	22	18.1	14.5	10.8	2.5	1.7	1.2	0.99
		70	VC	0.79	101	59	47	39	29	23	19.6	15.6	11.7	2.7	1.8	1.3	1.1
		80	VC	0.85	109	63	50	42	32	25	21	16.8	12.6	2.9	1.9	1.5	1.2
		90	VC	0.90	115	67	53	45	33	27	22	17.8	13.4	3.1	2.0	1.5	1.2
		100	C	0.95	122	71	56	47	35	28	24	18.8	14.1	3.2	2.2	1.6	1.3
WHITE	11008-VP (50 MESH)	15	UC	0.49	63	36	29	24	18.2	14.6	12.1	9.7	7.3	1.7	1.1	0.83	0.67
		20	UC	0.57	73	42	34	28	21	16.9	14.1	11.3	8.5	1.9	1.3	0.97	0.78
		30	UC	0.69	88	51	41	34	26	20	17.1	13.7	10.2	2.3	1.6	1.2	0.94
		40	XC	0.80	102	59	48	40	30	24	19.8	15.8	11.9	2.7	1.8	1.4	1.1
		50	XC	0.89	114	66	53	44	33	26	22	17.6	13.2	3.0	2.0	1.5	1.2
		60	VC	0.98	125	73	58	49	36	29	24	19.4	14.6	3.3	2.2	1.7	1.3
		70	VC	1.06	136	79	63	52	39	31	26	21	15.7	3.6	2.4	1.8	1.4
		80	VC	1.13	145	84	67	56	42	34	28	22	16.8	3.8	2.6	1.9	1.5
		90	VC	1.20	154	89	71	59	45	36	30	24	17.8	4.1	2.7	2.0	1.6
		100	C	1.26	161	94	75	62	47	37	31	25	18.7	4.3	2.9	2.1	1.7
LIGHT BLUE	11010-VP	15	UC	0.61	78	45	36	30	23	18.1	15.1	12.1	9.1	2.1	1.4	1.0	0.83
		20	UC	0.71	91	53	42	35	26	21	17.6	14.1	10.5	2.4	1.6	1.2	0.97
		30	UC	0.87	111	65	52	43	32	26	22	17.2	12.9	3.0	2.0	1.5	1.2
		40	XC	1.00	128	74	59	50	37	30	25	19.8	14.9	3.4	2.3	1.7	1.4
		50	XC	1.12	143	83	67	55	42	33	28	22	16.6	3.8	2.5	1.9	1.5
		60	VC	1.22	156	91	72	60	45	36	30	24	18.1	4.2	2.8	2.1	1.7
		70	VC	1.32	169	98	78	65	49	39	33	26	19.6	4.5	3.0	2.2	1.8
		80	VC	1.41	180	105	84	70	52	42	35	28	21	4.8	3.2	2.4	1.9
		90	VC	1.50	192	111	89	74	56	45	37	30	22	5.1	3.4	2.6	2.0
		100	C	1.58	202	117	94	78	59	47	39	31	23	5.4	3.6	2.7	2.2

DESCRIPTION:
**GALLONS PER ACRE
TABULATION FOR
TT1110 _-VP
TURBO TEEJET® AIR INDUCTION
POLYMER FLAT SPRAY TIP**



REVISION NO.	DATASHEET		
REFERENCE:	DS56525		
11/20/19	SHEET: 3 OF 3	DWG SIZE: A	