

AITTJ60 TeeJet®

*SEE DATA SHEET DS55255M TO REFERENCE SMALL CAPACITY AITTJ60 SPRAY TIPS

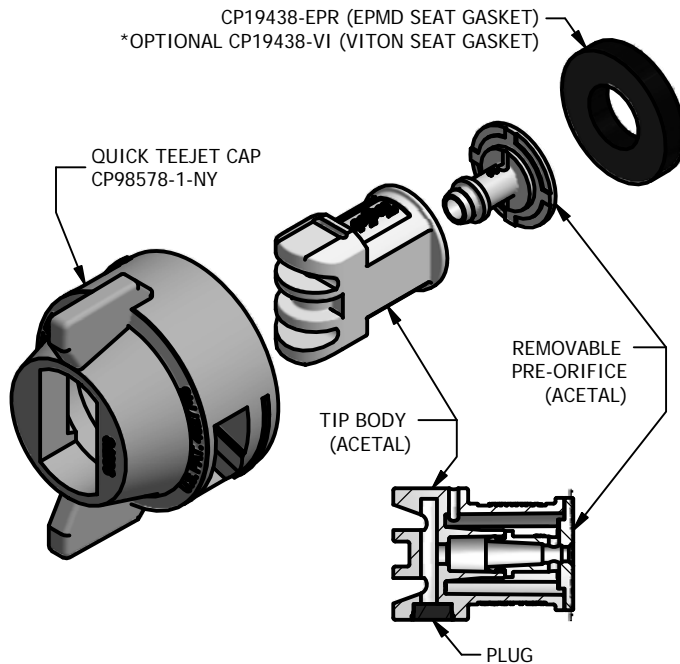

FEATURES:

- TIP PRODUCES 110° DUAL, TAPERED EDGE, WIDE ANGLE, FLAT SPRAY PATTERNS FOR UNIFORM COVERAGE IN BROADCAST SPRAYING
- DUAL ANGLE SPRAY PATTERNS HELP TO PENETRATE THE CROP CANOPY AND PROVIDE THOROUGH LEAF COVERAGE
- LARGE DROPLETS ARE PRODUCED THROUGH THE USE OF A VENTURI AIR ASPIRATOR, RESULTING IN LESS DRIFT
- LARGE, ROUND FREE PASSAGES MINIMIZE CLOGGING
- ALL ACETAL CONSTRUCTION FOR EXCELLENT CHEMICAL AND WEAR RESISTANCE
- REMOVABLE PRE-ORIFICE FOR FAST AND EASY CLEANING
- AUTOMATIC ALIGNMENT WITH USE OF CP98578-1-NY CAP
- TO INSTALL - ALIGN TIP BARREL WITH CAP FLATS AND PRESS IN UNTIL TIP BOTTOMS OUT
- SUGGESTED SPRAY PRESSURE RANGE 1.5-6 BAR

TYPICAL APPLICATIONS:

- EXCELLENT FOR MORE INTENSIVE PENETRATION OF THICK FOLIAGE AND ACHIEVING HIGH RATES OF COVERAGE WITH SYSTEMIC HERBICIDES
- VERY GOOD FOR PRE-EMERGE SURFACE APPLIED HERBICIDES

SPRAY ANGLE	OPTIMUM SPRAY HEIGHT	
	50cm SPACING	75cm SPACING
110°	50cm	75cm

TIP COLOR	TIP NO. (STRAINER SCREEN SIZE)	LIQUID PRESSURE (bar)	DROP SIZE CLASSIFICATION	CAPACITY 1 NOZZLE (l/min)	LITERS PER HECTARE 50 cm SPACING									
					4 km/h	5 km/h	6 km/h	7 km/h	8 km/h	10 km/h	12 km/h	16 km/h	20 km/h	
WHITE	AITTJ60-11008VP (50 MESH)	1.0	UC	1.82	546	437	364	312	273	218	182	137	109	
		1.5	UC	2.23	669	535	446	382	335	268	223	167	134	
		2.0	UC	3.16	948	758	632	542	474	379	316	237	190	
		3.0	XC	3.16	948	758	632	542	474	379	316	237	190	
		4.0	XC	3.65	1095	876	730	626	548	438	365	274	219	
		5.0	VC	4.08	1224	979	816	699	612	490	408	306	245	
		6.0	VC	4.47	1341	1073	894	766	671	536	447	335	268	
LIGHT BLUE	AITTJ60-11010VP	1.0	UC	2.28	684	547	456	391	342	274	228	171	137	
		1.5	UC	2.79	837	670	558	478	419	335	279	209	167	
		2.0	UC	3.95	1185	948	790	677	593	474	395	296	237	
		3.0	UC	3.95	1185	948	790	677	593	474	395	296	237	
		4.0	XC	4.56	1368	1094	912	782	684	547	456	342	274	
		5.0	XC	5.10	1530	1224	1020	874	765	612	510	383	306	
		6.0	VC	5.59	1677	1342	1118	958	839	671	559	419	335	
LIGHT GREEN	AITTJ60-11015VP	1.0	UC	3.42	1026	821	684	586	513	410	342	257	205	
		1.5	UC	4.19	1257	1006	838	718	629	503	419	314	251	
		2.0	UC	5.92	1776	1421	1184	1015	888	710	592	444	355	
		3.0	UC	5.92	1776	1421	1184	1015	888	710	592	444	355	
		4.0	XC	6.84	2052	1642	1368	1173	1026	821	684	513	410	
		5.0	XC	7.64	2292	1834	1528	1310	1146	917	764	573	458	
		6.0	VC	8.37	2511	2009	1674	1435	1256	1004	837	628	502	
		7.0	VC	9.04	2712	2170	1808	1550	1356	1085	904	678	542	

TABULATION BASED ON SPRAYING WATER AT 70° F.

DROPLET SIZE CLASSIFICATIONS ARE BASED ON ASABE STANDARD S-572.1 AT THE DATE OF PRINTING. CLASSIFICATIONS ARE SUBJECT TO CHANGE.

DROPLET SIZE CATEGORIES							
XF	VF	F	M	C	VC	XC	UC
EXTREMELY FINE	VERY FINE	FINE	MEDIUM	COARSE	VERY COARSE	EXTREMELY COARSE	ULTRA COARSE

DESCRIPTION:

LITERS PER HECTARE TABULATION FOR HIGH CAPACITY AITTJ60-110__-VP AIR INDUCTION TURBO TWINJET® SPRAY TIP



Spraying Systems Co.®
Spray Nozzles and Accessories
P.O. Box 7900 - Wheaton, IL 60189-7900

REVISION NO.	DATA SHEET	
REFERENCE:	DS55260M	
SHEET:	1 OF 1	DWG SIZE: A