

AITTJ60 TeeJet®

*SEE DATA SHEET DS55255 TO REFERENCE SMALL CAPACITY AITTJ60 SPRAY TIPS

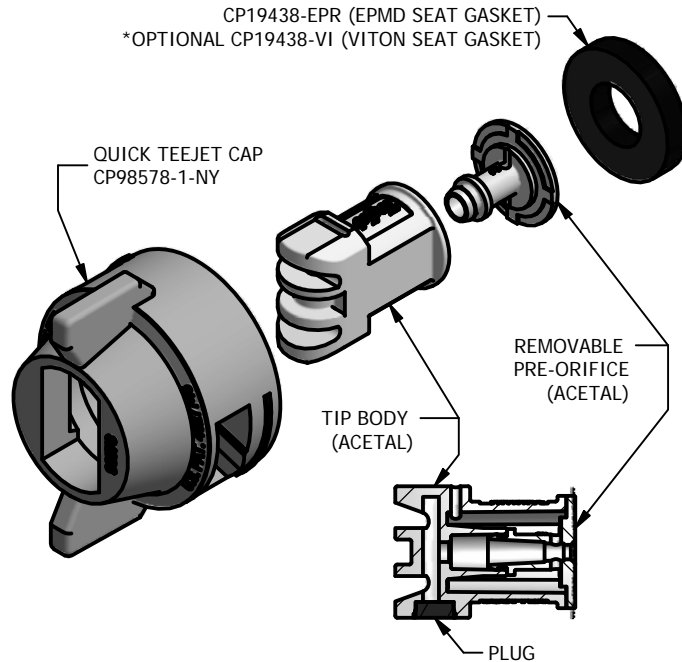

FEATURES:

- TIP PRODUCES 110° DUAL, TAPERED EDGE, WIDE ANGLE, FLAT SPRAY PATTERNS FOR UNIFORM COVERAGE IN BROADCAST SPRAYING
- DUAL ANGLE SPRAY PATTERNS HELP TO PENETRATE THE CROP CANOPY AND PROVIDE THOROUGH LEAF COVERAGE
- LARGE DROPLETS ARE PRODUCED THROUGH THE USE OF A VENTURI AIR ASPIRATOR, RESULTING IN LESS DRIFT
- LARGE, ROUND FREE PASSAGES MINIMIZE CLOGGING
- ALL ACETAL CONSTRUCTION FOR EXCELLENT CHEMICAL AND WEAR RESISTANCE
- REMOVABLE PRE-ORIFICE FOR FAST AND EASY CLEANING
- AUTOMATIC ALIGNMENT WITH USE OF CP98578-1-NY CAP
- TO INSTALL - ALIGN TIP BARREL WITH CAP FLATS AND PRESS IN UNTIL TIP BOTTOMS OUT
- SUGGESTED SPRAY PRESSURE RANGE 20-90 PSI

TYPICAL APPLICATIONS:

- EXCELLENT FOR MORE INTENSIVE PENETRATION OF THICK FOLIAGE AND ACHIEVING HIGH RATES OF COVERAGE WITH SYSTEMIC HERBICIDES
- VERY GOOD FOR PRE-EMERGE SURFACE APPLIED HERBICIDES

SPRAY ANGLE	OPTIMUM SPRAY HEIGHT	
	20" SPACING	30" SPACING
110°	20"	30"

TIP COLOR	TIP NO. (STRAINER SCREEN SIZE)	LIQUID PRESSURE (PSI)	DROP SIZE CLASSIFICATION	CAPACITY 1 NOZZLE (GPM)	CAPACITY 1 NOZZLE (oz/min)	GALLONS PER ACRE 20" SPACING							
						5 mph	6 mph	7 mph	8 mph	10 mph	12 mph	15 mph	20 mph
WHITE	AITTJ60-11008VP (50 MESH)	20	UC	0.57	73	42	34	28	21	16.9	14.1	11.3	8.5
		30	UC	0.69	88	51	41	34	26	20	17.1	13.7	10.2
		40	XC	0.80	102	59	48	40	30	24	19.8	15.8	11.9
		50	XC	0.89	114	66	53	44	33	26	22	17.6	13.2
		60	VC	0.98	125	73	58	49	36	29	24	19.4	14.6
		70	VC	1.06	136	79	63	52	39	31	26	21	15.7
		80	VC	1.13	145	84	67	56	42	34	28	22	16.8
LIGHT BLUE	AITTJ60-11010VP	90	C	1.20	154	89	71	59	45	36	30	24	17.8
		20	UC	0.71	91	53	42	35	26	21	17.6	14.1	10.5
		30	UC	0.87	111	65	52	43	32	26	22	17.2	12.9
		40	UC	1.00	128	74	59	50	37	30	25	19.8	14.9
		50	XC	1.12	143	83	67	55	42	33	28	22	16.6
		60	XC	1.22	156	91	72	60	45	36	30	24	18.1
		70	XC	1.32	169	98	78	65	49	39	33	26	19.6
LIGHT GREEN	AITTJ60-11015VP	80	XC	1.41	180	105	84	70	52	42	35	28	21
		90	VC	1.50	192	111	89	74	56	45	37	30	22
		20	UC	1.06	136	79	63	52	39	31	26	21	15.7
		30	UC	1.30	166	97	77	64	48	39	32	26	19.3
		40	UC	1.50	192	111	89	74	56	45	37	30	22
		50	XC	1.68	215	125	100	83	62	50	42	33	25
		60	XC	1.84	236	137	109	91	68	55	46	36	27
70	XC	1.98	253	147	118	98	74	59	49	39	29		
80	VC	2.12	271	157	126	105	79	63	52	42	31		
90	VC	2.25	288	167	134	111	84	67	56	45	33		

TABULATION BASED ON SPRAYING WATER AT 70° F.

DROPLET SIZE CLASSIFICATIONS ARE BASED ON ASABE STANDARD S-572.1 AT THE DATE OF PRINTING. CLASSIFICATIONS ARE SUBJECT TO CHANGE.

DROPLET SIZE CATEGORIES							
XF	VF	F	M	C	VC	XC	UC
EXTREMELY FINE	VERY FINE	FINE	MEDIUM	COARSE	VERY COARSE	EXTREMELY COARSE	ULTRA COARSE

DESCRIPTION:

GALLONS PER ACRE TABULATION FOR HIGH CAPACITY AITTJ60-110__-VP AIR INDUCTION TURBO TWINJET® SPRAY TIP



Spraying Systems Co.®
 Spray Nozzles and Accessories
 P.O. Box 7900 - Wheaton, IL 60189-7900

REVISION NO.	DATA SHEET	
REFERENCE:	DS55260	
SHEET: 1 OF 1	DWG SIZE: A	