

AITX ConeJet®

AIR INDUCTION HOLLOW CONE SPRAY TIP
WITH **VisiFlo®** COLOR CODING

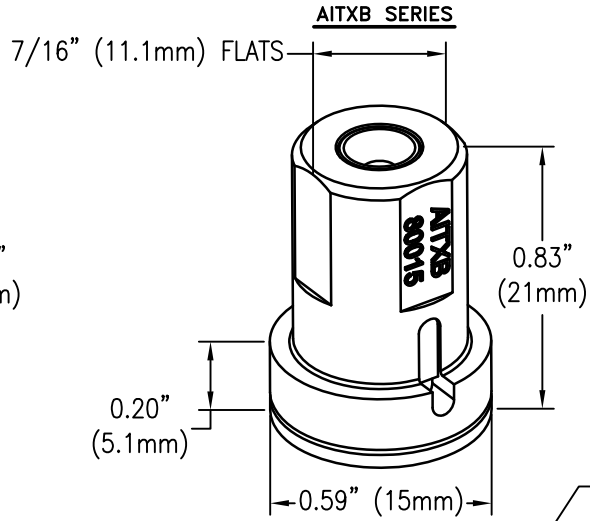
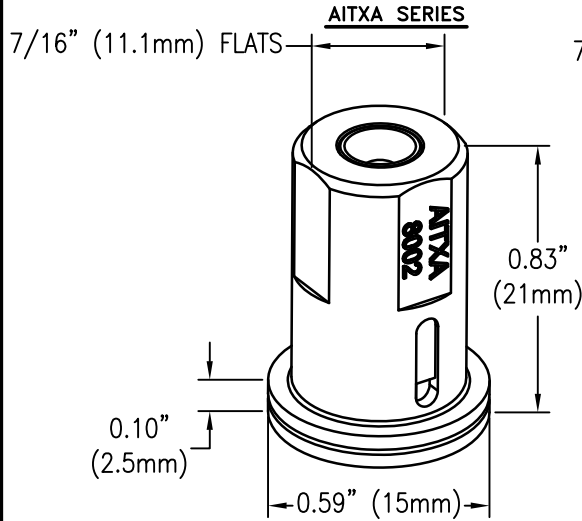

FEATURES:

- CONSTRUCTED OF POLYPROPYLENE, CERAMIC, AND VITON® FOR EXCELLENT CHEMICAL & WEAR RESISTANCE.
- REMOVABLE PRE-ORIFICE FOR FAST AND EASY CLEANING.
- AVAILABLE IN VISIFLO CERAMIC (VK).
- HOLLOW CONE SPRAY PATTERN IS IDEAL FOR AIRBLAST AND DIRECTED SPRAY APPLICATIONS.
- LARGER DROPLETS ARE PRODUCED, AS COMPARED TO STANDARD TX CONEJET, THROUGH THE USE OF A VENTURI AIR ASPIRATOR RESULTING IN REDUCED DRIFT AND IMPROVED CANOPY PENETRATION.
- IDEAL FOR SPRAYERS EQUIPPED WITH AUTOMATIC CONTROL SYSTEMS.
- AITXA TO BE USED WITH CP25607-*--NY QUICK TEEJET CAP.
- AITXB TO BE USED WITH ALBUZ CAPS OR CP26277-*--NY.
- SUGGESTED SPRAY PRESSURE RANGE: 60-300 PSI (4-20 BAR).

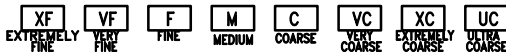
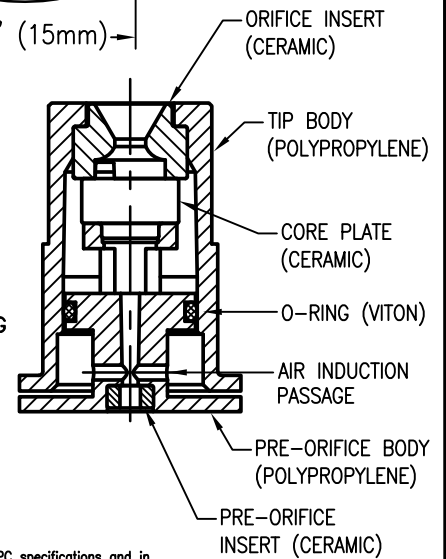

Droplet size classifications are based on BCPC specifications and in accordance with ASABE Standard S-572.1 at the date of printing. Classifications are subject to change.

CONEJET TIP TYPE	PART NUMBER	TIP COLOR	STRAINER MESH SIZE	CAPACITY IN L/MIN AT PRESSURE (BAR)																
				4	5	6	7	8	9	10	11	12	13	14	15	16	17	18	19	20
AITXA8001VK	AITXB8001VK	ORANGE	50	0.449	0.499	0.545	0.586	0.625	0.661	0.695	0.727	0.758	0.787	0.816	0.843	0.869	0.895	0.920	0.944	0.967
				XC	XC	VC	VC	C	C	C	C	C	C	C	C	C	M	M	M	M
AITXA80015VK	AITXB80015VK	GREEN	50	0.674	0.753	0.824	0.889	0.950	1.01	1.06	1.11	1.16	1.21	1.25	1.30	1.34	1.38	1.42	1.46	1.49
				XC	XC	VC	VC	VC	C	C	C	C	C	C	C	C	C	C	M	M
AITXA8002VK	AITXB8002VK	YELLOW	50	0.920	1.03	1.13	1.22	1.30	1.38	1.46	1.53	1.60	1.67	1.73	1.79	1.85	1.91	1.96	2.02	2.07
				XC	XC	XC	XC	XC	VC	VC	VC	VC	C	C	C	C	C	C	C	C
AITXA80025VK	AITXB80025VK	VIOLET	50	1.12	1.25	1.37	1.48	1.58	1.67	1.77	1.85	1.93	2.01	2.09	2.16	2.23	2.30	2.37	2.43	2.49
				UC	UC	XC	XC	XC	XC	XC	XC	XC	XC	XC	VC	VC	VC	VC	VC	VC
AITXA8003VK	AITXB8003VK	BLUE	50	1.34	1.50	1.65	1.78	1.91	2.02	2.14	2.24	2.34	2.44	2.54	2.63	2.72	2.80	2.88	2.96	3.04
				UC	UC	XC	XC	XC	XC	XC	XC	XC	VC	VC	VC	VC	VC	VC	C	C
AITXA8004VK	AITXB8004VK	RED	50	1.79	2.00	2.20	2.38	2.54	2.70	2.85	2.99	3.13	3.26	3.38	3.50	3.62	3.74	3.85	3.95	4.06
				UC	UC	UC	XC	XC	XC	XC	XC	XC	XC	XC	VC	VC	VC	VC	VC	VC

VITON® IS A TRADEMARK OF DUPONT DOW ELASTOMERS.

TABULATION BASED ON SPRAYING WATER AT 21° C.

DESCRIPTION:

AITXA & AITXB CONEJET®
AIR INDUCTION
HOLLOW CONE
VISIFLO® SPRAY TIPS
(METRIC)



Spraying Systems Co.®
Spray Nozzles and Accessories
P.O. Box 7900 - Wheaton, IL 60189-7900

Rev. No. 2

Ref. 6/2/2010

DATA SHEET

55230M

SHEET OF