

AITX ConeJet®

AIR INDUCTION HOLLOW CONE SPRAY TIP
WITH **VisiFlo®** COLOR CODING

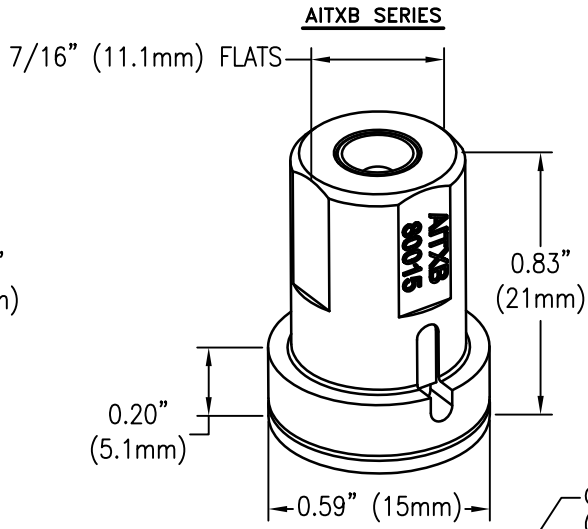
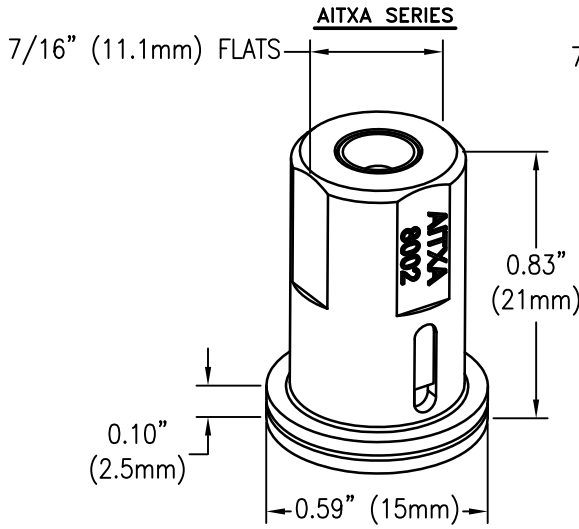

FEATURES:

- CONSTRUCTED OF POLYPROPYLENE, CERAMIC, AND VITON® FOR EXCELLENT CHEMICAL & WEAR RESISTANCE.
- REMOVABLE PRE-ORIFICE FOR FAST AND EASY CLEANING.
- AVAILABLE IN VISIFLO CERAMIC (VK).
- HOLLOW CONE SPRAY PATTERN IS IDEAL FOR AIRBLAST AND DIRECTED SPRAY APPLICATIONS.
- LARGER DROPLETS ARE PRODUCED, AS COMPARED TO STANDARD TX CONEJET, THROUGH THE USE OF A VENTURI AIR ASPIRATOR RESULTING IN REDUCED DRIFT AND IMPROVED CANOPY PENETRATION.
- IDEAL FOR SPRAYERS EQUIPPED WITH AUTOMATIC CONTROL SYSTEMS.
- AITXA TO BE USED WITH CP25607-*—NY QUICK TEEJET CAP.
- AITXB TO BE USED WITH ALBUZ CAPS OR CP26277-*—NY.
- SUGGESTED SPRAY PRESSURE RANGE: 60–300 PSI (4–20 BAR).

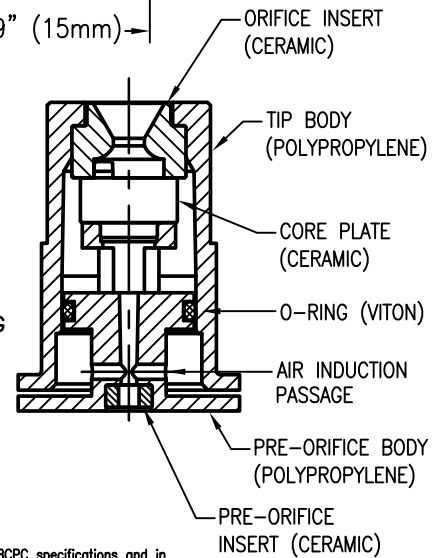

XF VF F M C VC XC UC
 EXTREMELY FINE VERY FINE FINE MEDIUM COARSE VERY COARSE EXTREMELY COARSE ULTRA COARSE

Droplet size classifications are based on BCPC specifications and in accordance with ASABE Standard S-572.1 at the date of printing. Classifications are subject to change.

CONEJET TIP PART NUMBER		TIP COLOR	STRAINER	CAPACITY IN GPM AT PRESSURE (PSI) & DROPLET SIZE																
TYPE AITXA	TYPE AITXB	VISIFLO	MESH SIZE	60	70	80	90	100	120	140	160	180	200	220	240	260	280	300		
AITXA8001VK	AITXB8001VK	ORANGE	50	0.121	0.130	0.138	0.146	0.154	0.168	0.181	0.192	0.203	0.214	0.224	0.233	0.242	0.251	0.260		
				XC	VC	VC	VC	VC	C	C	C	C	C	C	C	C	M	M	M	
AITXA80015VK	AITXB80015VK	GREEN	50	0.181	0.195	0.209	0.221	0.233	0.255	0.275	0.294	0.312	0.328	0.344	0.359	0.374	0.388	0.401		
				XC	XC	XC	VC	VC	C	C	C	C	C	C	C	C	M	M	M	
AITXA8002VK	AITXB8002VK	YELLOW	50	0.247	0.267	0.286	0.303	0.320	0.351	0.379	0.405	0.430	0.453	0.476	0.497	0.517	0.537	0.556		
				XC	XC	XC	XC	XC	VC	VC	VC	VC	C	C	C	C	C	C	C	
AITXA80025VK	AITXB80025VK	VIOLET	50	0.300	0.324	0.347	0.368	0.387	0.424	0.458	0.490	0.519	0.548	0.574	0.600	0.624	0.648	0.670		
				UC	UC	XC	XC	XC	XC	XC	XC	VC	VC	VC	VC	VC	VC	VC	C	
AITXA8003VK	AITXB8003VK	BLUE	50	0.360	0.389	0.417	0.443	0.467	0.513	0.554	0.594	0.630	0.665	0.698	0.730	0.760	0.790	0.818		
				UC	UC	XC	XC	XC	XC	XC	VC	VC	VC	VC	VC	VC	C	C	C	
AITXA8004VK	AITXB8004VK	RED	50	0.480	0.519	0.556	0.590	0.623	0.684	0.740	0.792	0.841	0.887	0.931	0.974	1.01	1.05	1.09		
				UC	UC	UC	UC	XC	XC	XC	XC	XC	VC	VC	VC	VC	VC	VC	VC	

VITON® IS A TRADEMARK OF DUPONT DOW ELASTOMERS.

TABULATION BASED ON SPRAYING WATER AT 70° F.

DESCRIPTION:

AITXA & AITXB CONEJET®
AIR INDUCTION
HOLLOW CONE
VISIFLO® SPRAY TIPS



Spraying Systems Co.®

Spray Nozzles and Accessories
P.O. Box 7900 - Wheaton, IL 60187-7901

Rev. No. 2

Ref. 6/2/2010

DATA SHEET

55230

SHEET OF