

SPECIFICATIONS AND FEATURES

- PLUNGER VALVE DESIGN FOR POSITIVE AND RELIABLE SHUTOFF
- 0.7 SEC SHUTOFF TIME FULLY OPEN TO FULLY CLOSED
- AVAILABLE IN 2-WAY VERSION WITH SIDE INLETS AND BOTTOM OUTLET
- 75 SERIES FLANGED INLETS ALLOWS FOR EASY ASSEMBLY OF MANIFOLDS AND ACCEPT A WIDE VARIETY OF FLANGE FITTINGS
- QUICK CONNECT OUTLET FITTING FOR RAPID ATTACHMENT AND REMOVAL OF BOOM LINES
- MAXIMUM PRESSURE RATING OF 175 PSI (12 BAR)
- FLOW RATE 27 GPM (102 l/min) AT 5 PSI (0.34bar) PRESSURE DROP
- FLOW RATE 38 GPM (144l/min) AT 10PSI (0.68bar) PRESSURE DROP
- WETTED PARTS ARE POLYPROPYLENE, NYLON, STAINLESS STEEL, AND VITON®
- INTEGRAL MOUNTING BRACKET ALLOWS FOR EASY INSTALLATION
- INTEGRATED 3-PIN METRI-PACK 150-SERIES SHROUD CONNECTOR ALLOWS FOR EASY ELECTRICAL HOOKUP. OPTIONAL 98546 ADAPTER CABLE AVAILABLE (SEE DS98546)

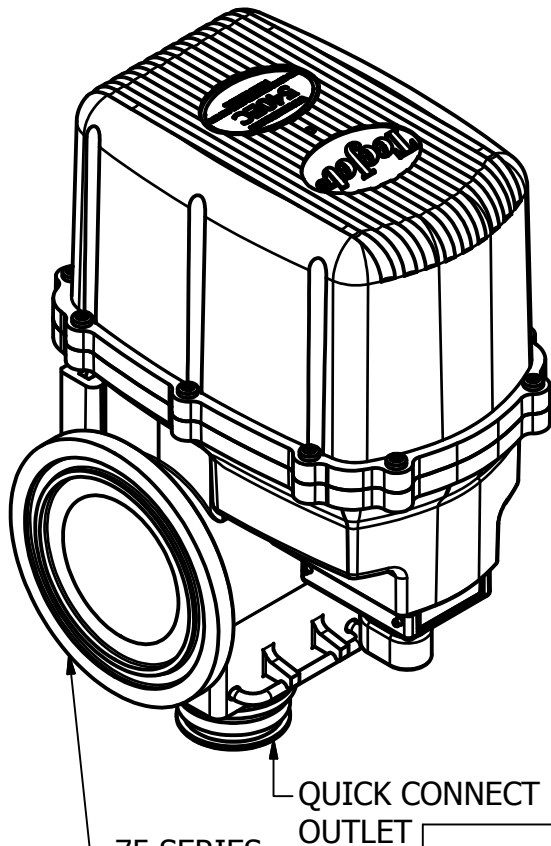

HOW TO ORDER

- 543EC-2 - THREE SECTION, POSITIVELY SWITCHED, 2-WAY VALVE
- 545E-2 - FIVE SECTION, DPDT SWITCHED, 2-WAY VALVE

75 SERIES
FLANGED INLETS
3" (76mm)

QUICK CONNECT
OUTLET

WIRING CHART

PIN	COLOR	EC MOTOR	E MOTOR
A	R	CONSTANT +12VDC	+12VDC TO OPEN
B	W	SWITCHED +12VDC (SIGNAL)	NOT USED
C	B	CONSTANT GROUND	-12VDC TO OPEN

3-PIN METRI-PACK 150 SHROUD CONNECTOR
*FOR "E" MOTORS REVERSE POLARITY TO CLOSE
(DPDT SWITCH)

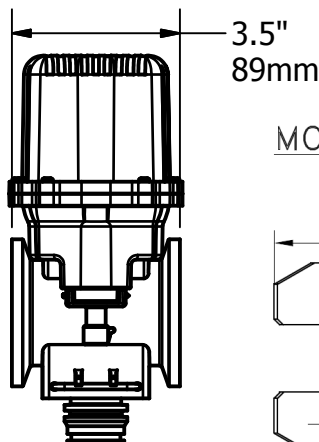
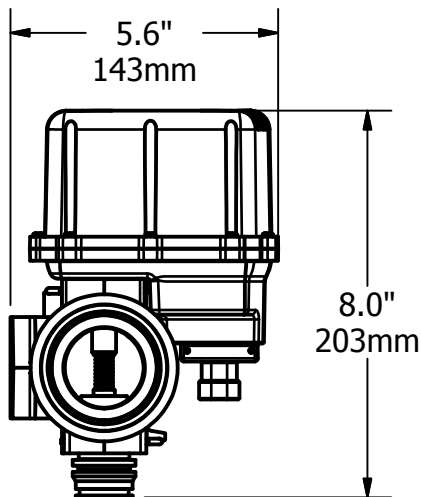
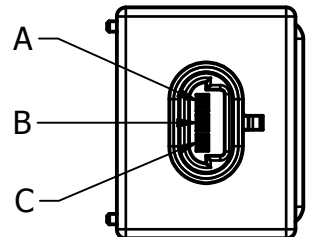

MOUNTING BRACKET SPECS:

BOTTOM VIEW

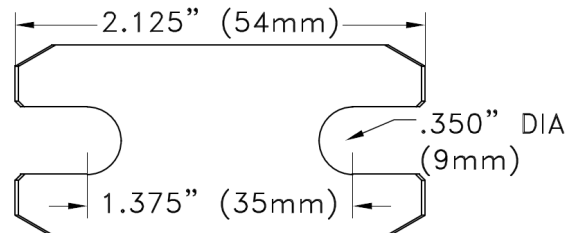

DESCRIPTION:

540EC and 540E
DIRECTOVALVE®
ELECTRIC SHUT-OFF
PLUNGER VALVE

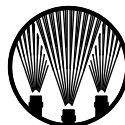

Spraying Systems Co.®
Spray Nozzles and Accessories
P.O. Box 7900 - Wheaton, IL 60189-7900

REVISION NO.

DATA SHEET

REFERENCE:

DS540

9/9/2011

SHEET: 1 OF 1

DWG SIZE:

A