

SPECIFICATIONS:

- MAXIMUM PRESSURE RATING: 290 PSI (20 BAR) FOR LARGE QUICK CONNECT, THREADED AND 50-SERIES FLANGED CONNECTIONS; 215 PSI (15 BAR) FOR 75-SERIES FLANGED CONNECTIONS
- FLOW RATE: 10 GPM @ 5 PSI (37.9 L/MIN @ 0.34 BAR) PRESSURE DROP
- FLOW RATE: 14 GPM @ 10 PSI (53.0 L/MIN @ 0.68 BAR) PRESSURE DROP
- WETTED MATERIALS: POLYPROPYLENE, NYLON, STAINLESS STEEL, FKM
- LENGTH: 2.3" (59 MM); WIDTH: 2.3" (59 MM); HEIGHT: 5.6" (142 MM) (HANDLE LENGTH: 3.6" (91 MM))

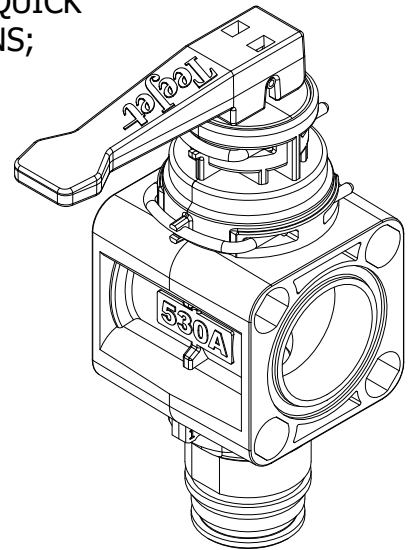

FEATURES INCLUDE:

- ERGONOMIC HANDLE DESIGN; SHOWN IN CLOSED POSITION
- QUICK RELEASE HANDLE ALLOWS FOR FIELD INSPECTION
- OUTLET CONNECTIONS AVAILABLE IN STRAIGHT OR 90° QUICK CONNECT HOSE BARBS; REFER TO PL45529
- STAINLESS STEEL STEM PROVIDES EXCELLENT DURABILITY AND CHEMICAL RESISTANCE
- STAINLESS STEEL MOUNTING BRACKETS ON EACH END ALLOW FOR EASY INSTALLATION
- INLET OPTIONS OF LARGE QUICK CONNECT, 50-SERIES OR 75-SERIES FLANGE AND 1-1/4" OR 1-1/2" FEMALE THREAD
- UPGRADABLE TO ELECTRIC VERSION BY REPLACING HANDLE ASSEMBLY WITH MOTOR ASSEMBLY

ORDERING INFORMATION:

115871: REPLACEMENT 2-WAY VALVE
 531AM-2: 1 SECTION MANIFOLD
 535AM-2: 5 SECTION MANIFOLD
 (PICTURED BELOW)

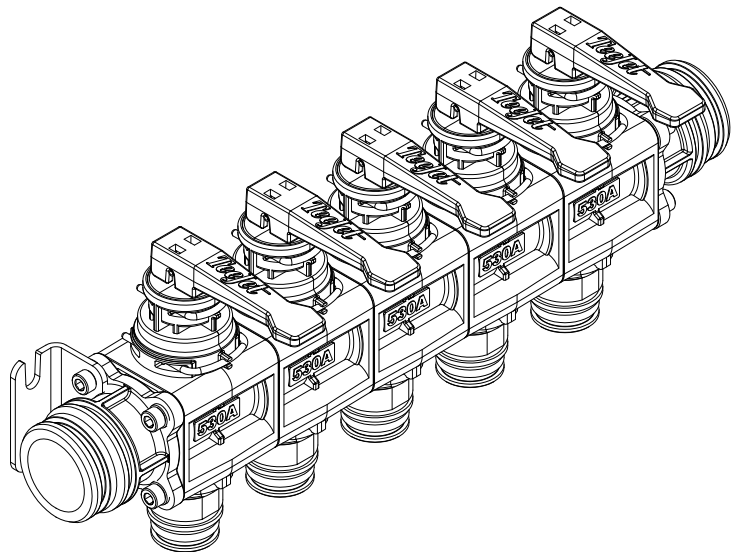

MOUNTING BRACKET
 (BOTTOM VIEW)

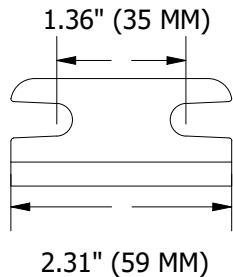

DESCRIPTION:

530AM
2-WAY DIRECTOVALVE
MANUAL SHUT-OFF
PLUNGER VALVE MANIFOLD



REVISION NO.	1	Data Sheet No.	
REFERENCE:	1/1/2020	DS530AM-2	
SHEET:	1 OF 1	DWG SIZE:	A