

The 4193B Check Valve Strainer provides a dual function of protecting the orifice tip from clogging as well as preventing the nozzle from dripping after the line pressure is shut-off.

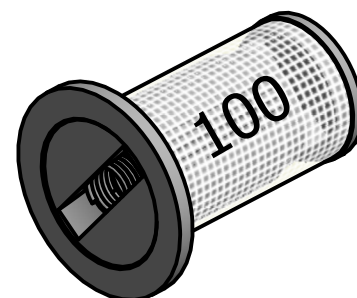
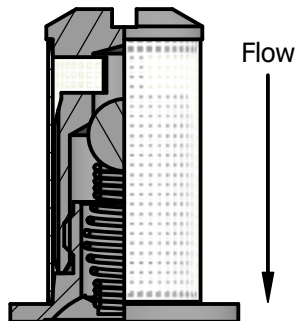
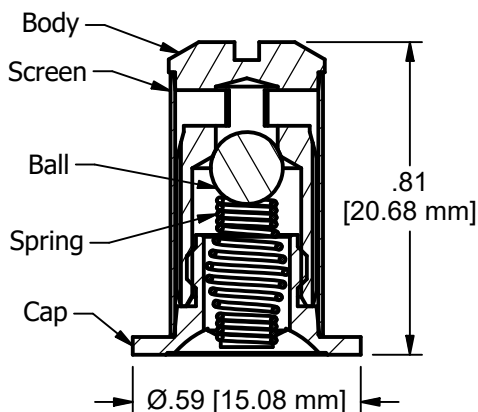

* Laser Marked Screen Mesh Size

How To Order:

Check Valve No.	Material		
	Body and Cap	Ball	Screen
4193B-* **SS	Brass	Stainless Steel	Stainless Steel
4193B-AL-* **SS	Aluminum	Stainless Steel	Stainless Steel
4193B-SS-* **SS	Stainless Steel	Stainless Steel	Stainless Steel
4193B-PP-* **SS	Polypropylene	Viton®	Stainless Steel
4193B-PP-* SS-**SS	Polypropylene	Stainless Steel	Stainless Steel

* Specify Spring Rating (5 or 10 PSI).
 [For Spring Rating (2, 20, or 40 PSI), See DS4193A.]
 ** Specify Screen Mesh Size - 24, 50, 80, 100 or 200.

Examples:

- 4193B-5-50SS Brass Body, 5 PSI Spring, 50 Mesh, Stainless Steel Ball
- 4193B-SS-10-80SS Stainless Body, 10 PSI Spring, 80 Mesh, Stainless Steel Ball
- 4193B-PP-5-100SS Polypropylene Body, 5 PSI Spring, 100 Mesh, Viton® Ball
- 4193B-PP-10-SS-100SS Polypropylene Body, 10 PSI Spring, 100 Mesh, Stainless Steel Ball

Mesh Color (Polypropylene Body Only):

Screen Mesh Size	24	50	80	100	200
Color					
Color Name	White	Gentian Blue	Zinc Yellow	Traffic Green	Light Pink

Pressure Drop:

Flow Rate (GPM)	0.3	0.4	0.6	0.8	1.0	1.5
Pressure Drop (PSI)	5	6	8	10	12	20

The 4193B Check Valve Strainers can be used with most flat spray, hollow cone spray, full cone spray and solid stream tips. Not compatible with TTI, AI or DG tips.

DESCRIPTION:

No. 4193B-_-_-SS
 Check Valve Strainer



Spraying Systems Co.®
 Spray Nozzles and Accessories
 P.O. Box 7900 - Wheaton, IL 60189-7900

REVISION NO.	1	Data Sheet No.	
REFERENCE:	115525, 115526	4193B	
SHEET:	OF	DWG SIZE:	A