

DIRECTIONS FOR ARMATURE STOP
ADJUSTMENTS FOR SOLENOID
OPERATED DIRECTOVALVE®
CONTROL VALVES.

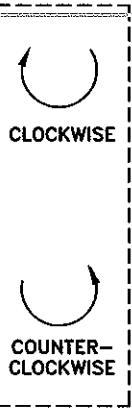

144, 144H, 144A, 145, 145H, 146 VALVES

- 1) UNSCREW JAM NUT BY TURNING IT COUNTER-CLOCKWISE.
- 2) SCREW THE ARMATURE STOP DOWN CLOCKWISE UNTIL SOLID CONTACT IS MADE WITH THE ARMATURE. THIS CAN BE NOTICED BY OBSERVING SLIGHT MOVEMENT OF THE LOWER DIAPHRAGM PISTON.
- 3) BACK OUT ARMATURE STOP BY TURNING COUNTER-CLOCKWISE. (SEE TABLE AT RIGHT FOR NUMBER OF TURNS).
- 4) LOCK JAM NUT IN PLACE BY TURNING IT CLOCKWISE, WHILE HOLDING ARMATURE STOP IN POSITION.
- 5) STROKE CAN BE CHECKED BY MEASURING THE TRAVEL OF THE LOWER DIAPHRAGM PISTON. (SEE TABLE FOR STROKE LENGTH)

144-1-3, 144A-1-3, 144F-1-3 VALVES

- 1) UNSCREW JAM NUT BY TURNING IT COUNTER-CLOCKWISE.
- 2) UNSCREW ARMATURE STOP BY TURNING IT COUNTER-CLOCKWISE UNTIL IT STOPS.
- 3) PUSH UP ON LOWER DIAPHRAGM PISTON, BY INSERTING NAIL PUNCH INTO HOLE IN BOTTOM HOLDER, UNTIL YOU FEEL THE SEAT WASHER MAKE CONTACT WITH THE BODY SEATING SURFACE. (SEE SHEET 2)
- 4) WHILE HOLDING THE LOWER DIAPHRAGM PISTON UP, TURN THE ARMATURE STOP CLOCKWISE UNTIL IT MAKES SOLID CONTACT WITH THE ARMATURE. (SEE SHEET 2)
- 5) BACK OUT ARMATURE STOP BY TURNING COUNTER-CLOCKWISE. (SEE TABLE AT RIGHT FOR NUMBER OF TURNS)
- 6) LOCK JAM NUT BY TURNING IT CLOCKWISE.

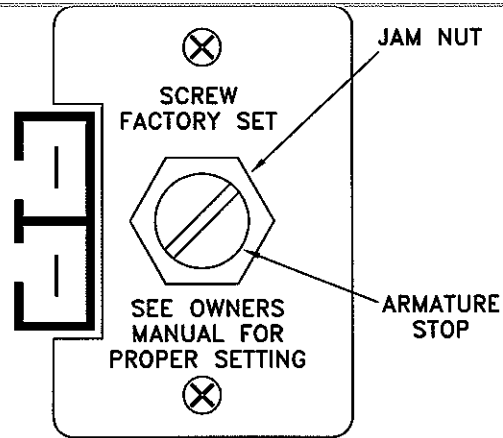

TYPICAL TOP VIEW OF 144, 144H, 144A, 144-1-3, 144A-1-3, 144F-1-3, 145, 145H AND 146 CONTROL VALVES.

VALVE No.	No. OF ARMATURE STOP TURNS	APPROX. STROKE LENGTH
144	2 1/2	1/8" (3.2 mm)
144H	1 1/2	5/64" (2 mm)
144A	2	7/64" (2.8 mm)
145	3 1/2	3/16" (4.8 mm)
145H	3	11/64" (4.4 mm)
146	5	1/4" (6.4 mm)
144-1-3	1/8	N/A
144A-1-3	1/8	N/A
144F-1-3	1/8	N/A

NOTE: 1 TURN OF THE ARMATURE STOP IS EQUAL TO 360° OF ROTATION.

TOOLS NEEDED FOR ADJUSTMENT

- 1) ADJUSTABLE WRENCH
- 2) FLAT HEAD SCREWDRIVER
- 3) NAIL PUNCH

DESCRIPTION:

ARMATURE STOP ADJUSTMENTS
FOR SOLENOID OPERATED
DIRECTOVALVE® CONTROL VALVES



Spraying Systems Co.®

Spray Nozzles and Accessories
P.O. Box 7900 - Wheaton, Il. 60189-7900

Rev. No. 1

Ref.

Data Sheet No.

38370

SHEET OF

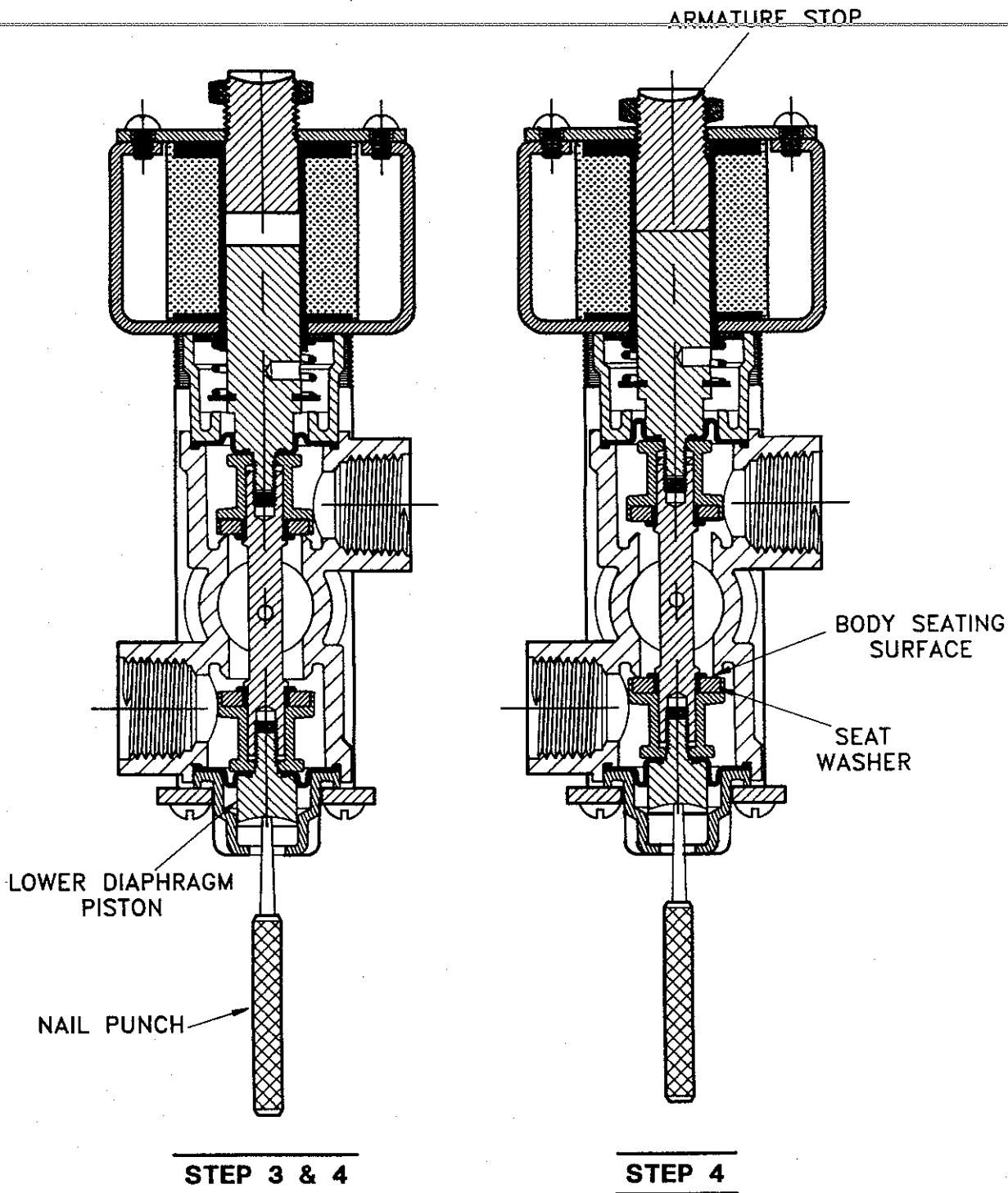

DESCRIPTION

**ARMATURE STOP ADJUSTMENTS
FOR THE 144A-1-3 DIRECTOVALVE®
CONTROL VALVES**



Spraying Systems Co.

Spray Nozzles and Accessories
North Avenue at Schmale Rd. • P.O. Box 7900
Wheaton, Il. 60189-7900

Ref:

Revision No.

Data Sheet No.

38370

SHEET 2