

TURBO

WIDE ANGLE FLAT SPRAY TIPS WITH TAPERED EDGE PATTERN

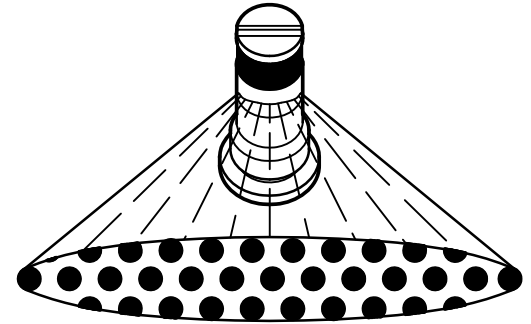

WIDE ANGLE FLAT SPRAY WITH TAPERED EDGE PATTERN

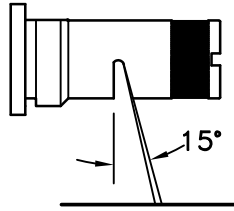
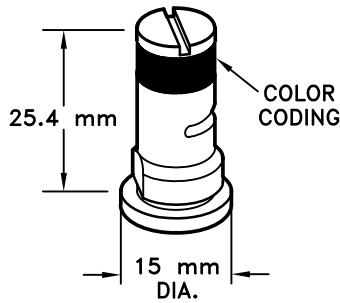
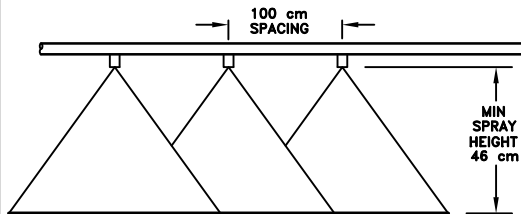

* ADJUST SPRAY HEIGHT IN THE FIELD TO OVERLAP A MINIMUM OF 30% OF EACH EDGE OF PATTERN.

FEATURES:

- EXCELLENT SPRAY DISTRIBUTION QUALITY.
- NOZZLE DESIGN INCORPORATES A PRE-ORIFICE TO PROVIDE LARGER DROPLETS FOR LESS DRIFT.
- WIDE SPRAY AT LOW PRESSURE.
- LARGE ORIFICE REDUCES CLOGGING.
- VisiFlo® COLOR-CODING FOR EASY SIZE IDENTIFICATION.
- MATERIAL: STAINLESS STEEL.
- CAN BE USED WITH No. CP25599--NY QUICK TEEJET® CAP FOR AUTOMATIC ALIGNMENT.

| TIP COLOR VisiFlo® | TIP No. (STRAINER MESH SIZE) | LIQUID PRESSURE IN bar | CAPACITY 1 NOZZLE IN l/min | LITERS PER HECTARE 100 cm SPACING | | | | DROP SIZE CLASSI- FICATION |
|-----------------------|------------------------------------|------------------------------|-------------------------------------|--------------------------------------|-----------|------------|------------|-------------------------------------|
| | | | | 6 km/h | 8 km/h | 10 km/h | 12 km/h | |
| RED | TF-VS2 (50 MESH) | 1 | 0.91 | 91.0 | 68.3 | 54.6 | 45.5 | UC |
| | | 1.5 | 1.12 | 112 | 84.0 | 67.2 | 56.0 | XC |
| | | 2 | 1.29 | 129 | 96.8 | 77.4 | 64.5 | XC |
| BROWN | TF-VS2.5 (50 MESH) | 1 | 1.14 | 114 | 85.5 | 68.4 | 57.0 | UC |
| | | 1.5 | 1.40 | 140 | 105 | 84.0 | 70.0 | UC |
| | | 2 | 1.61 | 161 | 121 | 96.6 | 80.5 | XC |
| GRAY | TF-VS3 (50 MESH) | 1 | 1.37 | 137 | 103 | 82.2 | 68.5 | UC |
| | | 1.5 | 1.67 | 167 | 125 | 100 | 83.5 | UC |
| | | 2 | 1.93 | 193 | 145 | 116 | 96.5 | XC |
| WHITE | TF-VS4 | 1 | 1.82 | 182 | 137 | 109 | 91.0 | UC |
| | | 1.5 | 2.23 | 223 | 167 | 134 | 112 | UC |
| | | 2 | 2.58 | 258 | 194 | 155 | 129 | UC |
| L. BLUE | TF-VS5 | 1 | 2.28 | 228 | 171 | 137 | 114 | UC |
| | | 1.5 | 2.79 | 279 | 209 | 167 | 140 | UC |
| | | 2 | 3.22 | 322 | 242 | 193 | 161 | UC |
| L. GREEN | TF-VS7.5 | 1 | 3.42 | 342 | 257 | 205 | 171 | UC |
| | | 1.5 | 4.19 | 419 | 314 | 251 | 210 | UC |
| | | 2 | 4.83 | 483 | 362 | 290 | 242 | UC |
| BLACK | TF-VS10 | 1 | 4.56 | 456 | 342 | 274 | 228 | UC |
| | | 1.5 | 5.58 | 558 | 419 | 335 | 279 | UC |
| | | 2 | 6.45 | 645 | 484 | 387 | 323 | UC |

DROPLET SIZE CATEGORIES

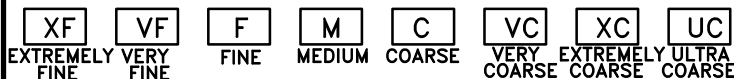

Droplet size classifications are based on ASABE Standard S-572.1 at the date of printing. Classifications are subject to change.

DESCRIPTION:

LITERS PER HECTARE
TABULATION FOR
TURBO FLOODJET
SPRAY TIPS
(METRIC)



Spraying Systems Co.®

Spray Nozzles and Accessories
P.O. Box 7900 - Wheaton, IL 60187-7901

Rev. No. 1

Ref. 4/13/2010

DATA SHEET

36394M

SHEET OF