

A

B

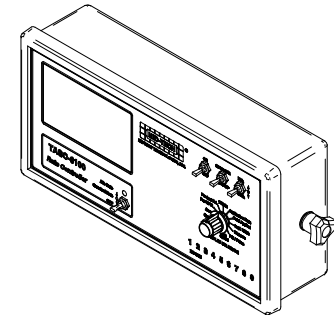
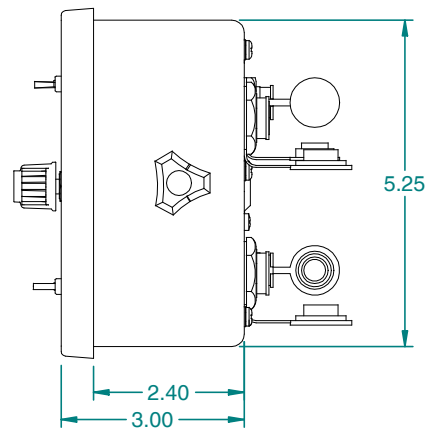
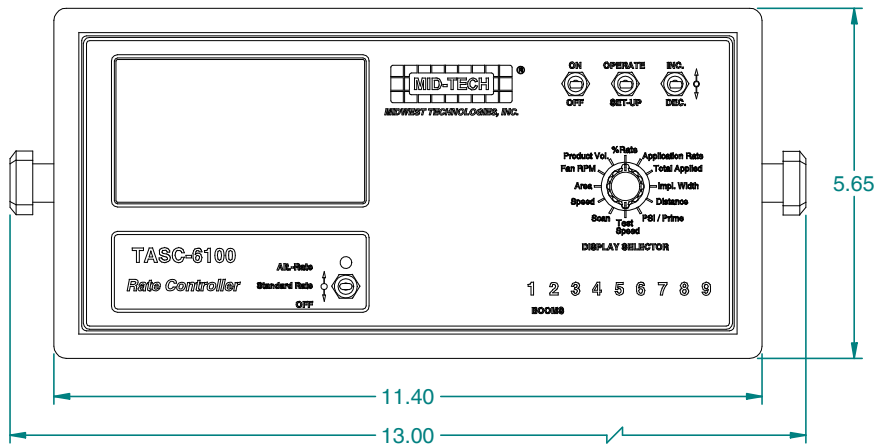

C

D



Notes: Features and Functions

- 4.00" L x 2.25" W Back-Lit LCD display.
- Liquid or Granular control
- Liquid-pressure or flowmeter
- Up to 9 boom sections
- Links to Mid-Tech Data Link for GPS/GIS applications
- Flash memory allows for field upgrades
- On-the-go rate change
- Ground speed override
- Liquid and Granular calibrations numbers stored independently
- Low tank or hopper alarm.
- English or Metric units
- Non-volatile memory
- CE Certified
- Displays speed, application rate, total applied, product volume remaining, width, fan rpm, distance, field area, and total area.
- Scan feature monitors all functions
- Error message system signals misapplication and identifies problem source

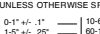
MATERIAL:		See Notes			
FINISH:		See Notes			
PROJECTION:		SCALE:	UNITS:	TITLE:	
		1:2	X	TASC 6100	
UNLESS OTHERWISE SPECIFIED TOLERANCE:		METRIC:		DRAWN BY:	
0-1" ± .1" 10-60" ± .1" .XX .02 1-5" ± .25" 60-120" ± .2" .XX .03 5-10" ± .5" 120" ± .3" .XX .05				CHECKED BY:	
R0 7/30/03		DATE		APPROVED BY:	
REV. DATE		NOC No		SHEET No: 1 of 1	
				DWG No: C-75-02013	
Midwest Technologies IL, LLC. Claims proprietary right in the material disclosed hereon. This document is not to be used in any way detrimental to the interest of Midwest Technologies IL, LLC.					