

A

B

C

D

TeeJet 801 FM Assemblies		Mid-Tech 801 FM Assemblies		Hose Connection Option	
P/N	Description	P/N	Description	P/N	Description
90-50231	801 w/ 3/4" HB	90-02175	801 w/ 3/4" HB	57-10112*	3/4" Hose Barb
90-50230	801 w/ 1" HB	90-02176	801 w/ 1" HB	57-10113*	1" Hose Barb
90-50232	801 w/1_1/4" HB	90-02177	801 w/1_1/4" HB	57-10114*	1_1/4" Hose Barb
90-50233	801 w/1_1/4" NPT (F)	90-02178	801 w/1_1/4" NPT (F)	57-10115*	1_1/4" NPT (F)
Above assemblies include flow meter interface cable 45-05315				(*) 2 Required per 57-10100 flow meter	
				Note: Also requires 2 flange clamp (50 series) assemblies 90-50229	

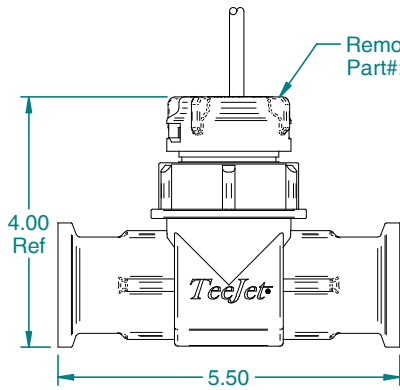

Removable Insert  
Part#: 90-02252

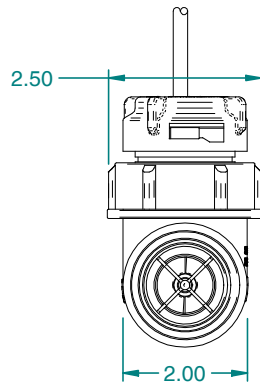

Calibration Number Label  
(2 Plcs)

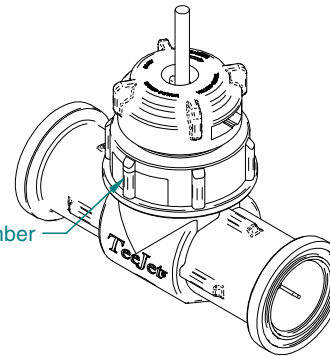

1

2

3

4

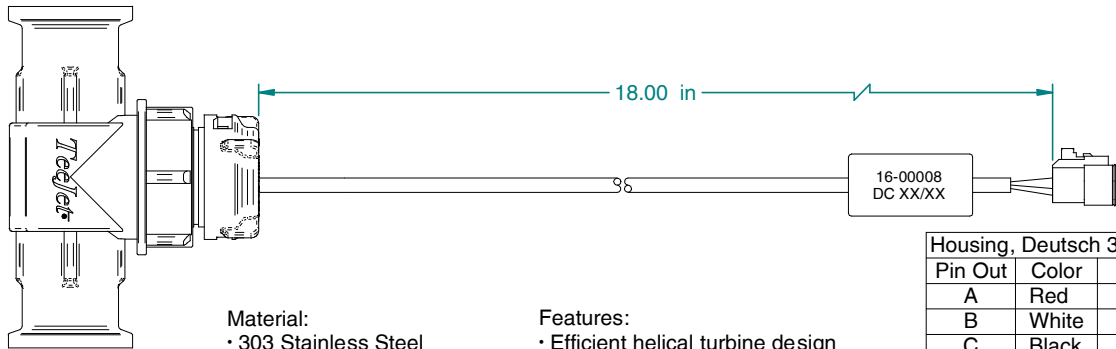

- Material:**
- 303 Stainless Steel
  - 410 Stainless Steel
  - Nylon
  - Polypropylene
  - Ruby
  - Sapphire

- Features:**
- Efficient helical turbine design
  - Easy access to turbine assembly for cleaning and maintenance
  - Flange mount design for flexible installation options
  - 2.5-60 GPM (10-225 LPM)

Housing, Deutsch 3 Pos/Skts		
Pin Out	Color	Function
A	Red	(+ 12v)
B	White	Signal
C	Black	Ground

**Notes:**

- Approximate calibration #82 pulses/lit - 310 pulses/gal.
- Vertical mounting position recommended
- 12 inches (30cm) of uninterrupted flow required before the flow meter and 6 inches (15cm) of uninterrupted flow required after flow meter.
- 45-05315 Flow meter interface cable required for Mid-Tech controls.

MATERIAL:		See Notes			
FINISH:		See Notes		TITLE: Flowmeter, 801	
PROJECTION:		SCALE: UNITS: X		DRAWN BY: <i>Rayan Reiser</i>	
UNLESS OTHERWISE SPECIFIED TOLERANCE:		METRIC: 2:1		CHECKED BY: <i>Ann Lindner</i>	
R1	6/15/05	UpDated	0.1" ± .01"	10-60" ± .1"	XX
R0	8/14/02	010117	1-5" ± .05"	60-120" ± .1"	XXX
REV.	DATE	NOC. No	5-10" ± .5"	120" ± .3"	Z
			SHEET No: <b>1 of 2</b>		DWG No: <b>C-57-10100</b>
Midwest Technologies IL, LLC. Claims proprietary right in the material disclosed herein. This document is not to be used in any way detrimental to the interest of Midwest Technologies IL, LLC.					

A

Item	Description	Part Number	QTY	U.M.
1	Sensor, PCB Assembly	16-00008	1	EA
2	O-Ring, 35mmx3mm	57-00065	1	EA
3	Turbine Assembly 801 FM	57-10108	1	EA
4	Guide Vane Bearing	57-10109	2	EA
5	Washer, Seat, 801	57-10111	1	EA
6	Screw, #6-5/8" LG Flat Head	60-04031	2	EA
7	Body, 801 Flowmeter	64-50044	1	EA
8	Endcap, 801 Flowmeter	64-50045	1	EA
9	Retaining, Nut 801 FM	64-50046	1	EA
10	Insert, Body 801 FM	64-50047	1	EA

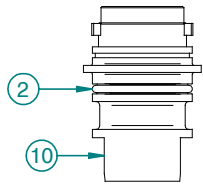

B

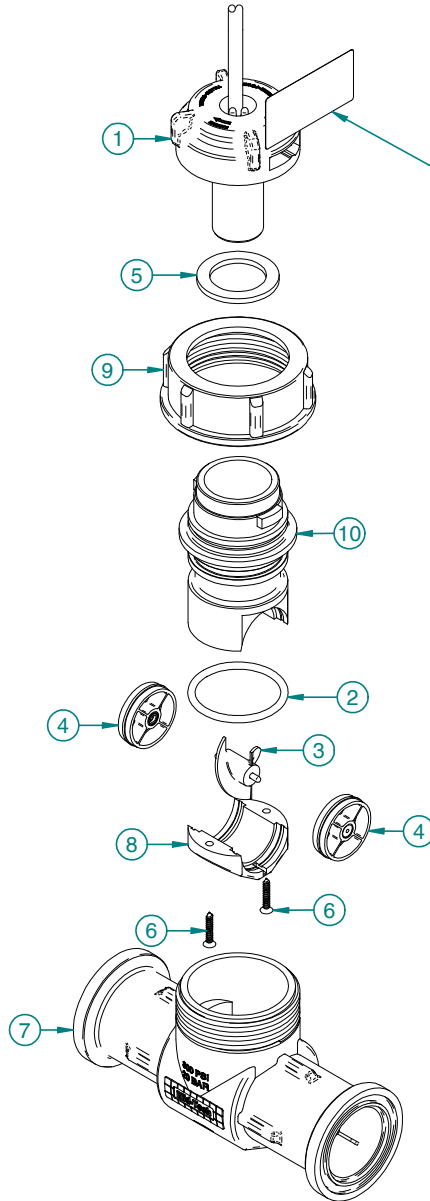

C

Approximate Calibration #'s  
 TeeJet - 82  
 Mid-Tech - 310  
 2-60 gpm DC:xx/xx

D

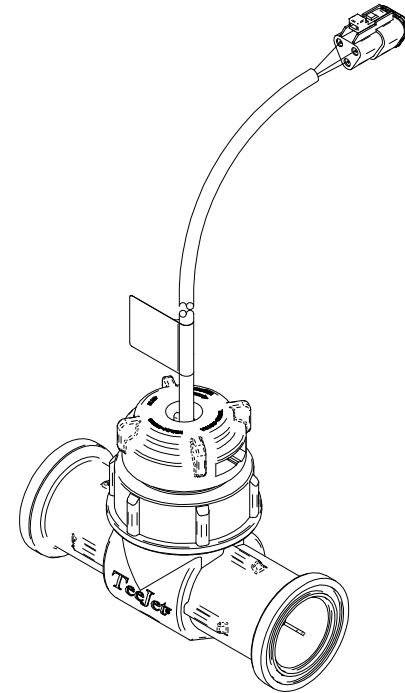

1

2

3

4

MATERIAL:		N/A			
FINISH:		N/A		TITLE: Flowmeter, 801	
PROJECTION:		SCALE: UNITS: X		DRAWN BY: <i>Rayan Reiser</i>	
		2:1 INCH: X		CHECKED BY: <i>Ann Hopkins</i>	
UNLESS OTHERWISE SPECIFIED TOLERANCE:		METRIC: X		APPROVED BY: <i>Scott Leander</i>	
R1	6/15/05	UpDated	0-1" +/- .1"	10-60" +/- 1"	XX
R0	8/14/02	010117	1-5" +/- .25"	60-120" +/- 2"	XXX
REV.	DATE	NOC. No	5-10" +/- .5"	120" +/- 3"	Z
			SHEET No: 2of2 DWG No: C-57-10100		
Midwest Technologies IL, LLC. Claims proprietary right in the material disclosed herein. This document is not to be used in any way detrimental to the interest of Midwest Technologies IL, LLC.					