

A

B

C

D

| Item | Description | Part Number | QTY | U.M. |
|------|--|-------------|-----|------|
| 1 | DECAL, CHEMICAL TANK ID | 102-0110 | 1 | EA |
| 2 | TANK, 7.5 GALLON, AS PURCHASED | 160-0002 | 1 | EA |
| 3 | LATCH PLATE, SST | 160-0003 | 1 | EA |
| 4 | HEEL PLATE, SST 7.5gal TANKS | 160-0004 | 1 | EA |
| 5 | COUPLING, NIPPLE, 1/2" SST FEMALE THREAD | 160-0007 | 1 | EA |
| 6 | TUBE, SUCTION, PP .75" ID X 12.5" LONG | 160-0009 | 1 | EA |
| 7 | BAFFLE, SST SUCTION | 160-0010 | 1 | EA |
| 8 | LID, 5" | 160-0016 | 1 | EA |
| 9 | SCREW MACH., 8/32 x 1/2" SST, - R.H. PH | 307-0010 | 2 | EA |
| 10 | WASHER, FLAT, 1/4" SST 5/8" O.D | 350-0024 | 4 | EA |
| 11 | BOLT HEX 1/4-20 x 1/2 SST | 350-0100 | 4 | EA |
| 12 | ROPE, PP BRAIDED YELLOW 1/8" DIAMETER | 600-0059 | 21 | IN |
| 13 | NIPPLE, REDUCING PP 3/4" x 1/2" | 822-0001 | 1 | EA |
| 14 | FITTING, BLKHD 3/4" | 835-0001 | 1 | EA |
| 15 | CABLE TIE, 5-3/4" x .10" | 844-9000 | 1 | EA |

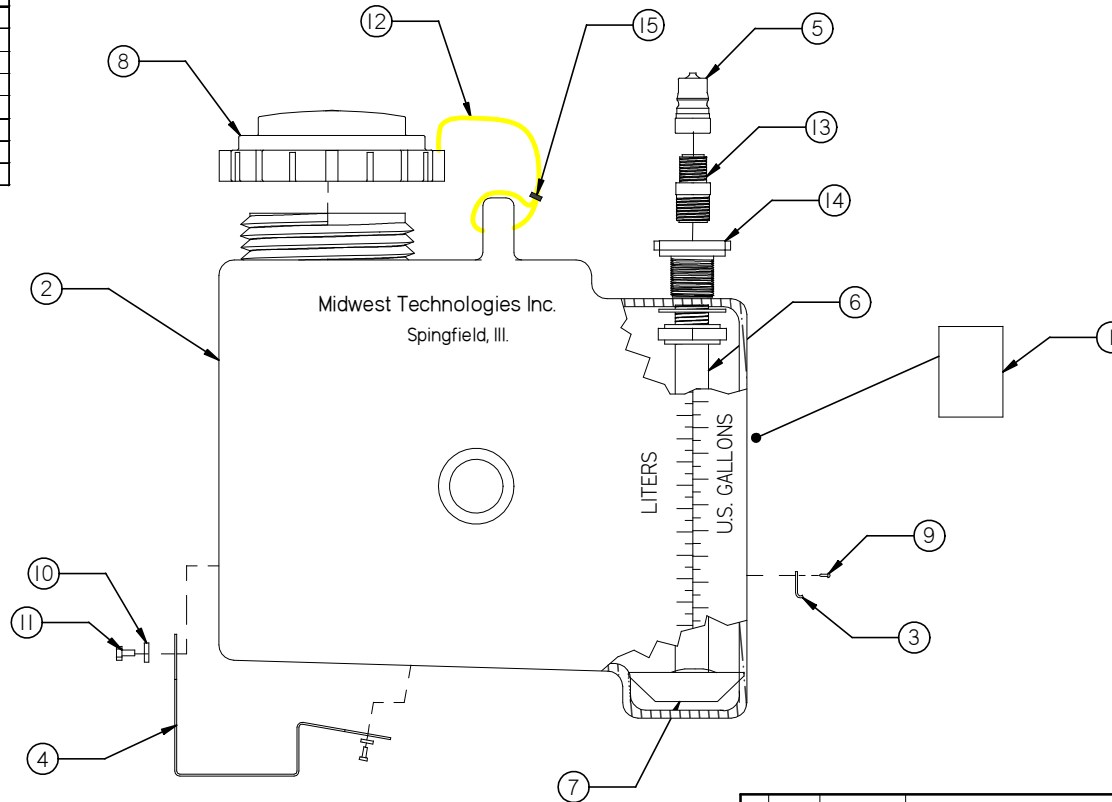

| | | | | |
|------|----------|-----------|----|---|
| | | MATERIAL: | NA | |
| | | FINISH: | NA | |
| R5 | 8/31/98 | 98097-8 | | TITLE: TANK, 7.5GAL. .5" FITTING |
| R4 | 12/10/97 | 97318-10 | | DRAWN BY: <i>Bryan Reiser</i> |
| R3 | 6/24/98 | UP DATED | | CHECKED BY: <i>Miss Irwin</i> |
| R2 | 6/2/97 | UP DATED | | APPROVED BY: <i>Erica Saterius</i> |
| R1 | 7/11/91 | UP DATED | | SHEET No: 1 of 2 DWG No: C-160-0001 |
| RO | 1/2/90 | RELEASED | | |
| REV. | DATE | NO. No. | | |

Midwest Technologies IL, LLC. Claims proprietary right in the material disclosed hereon. This document is not to be used in any way detrimental to the interest of Midwest Technologies IL, LLC.

A

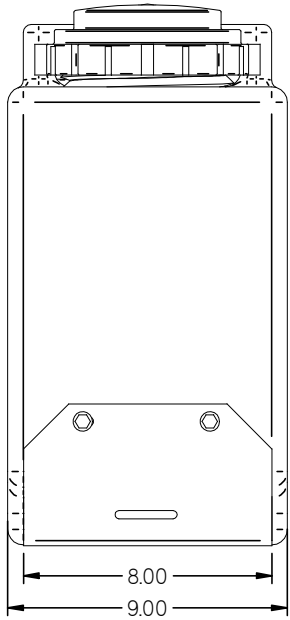

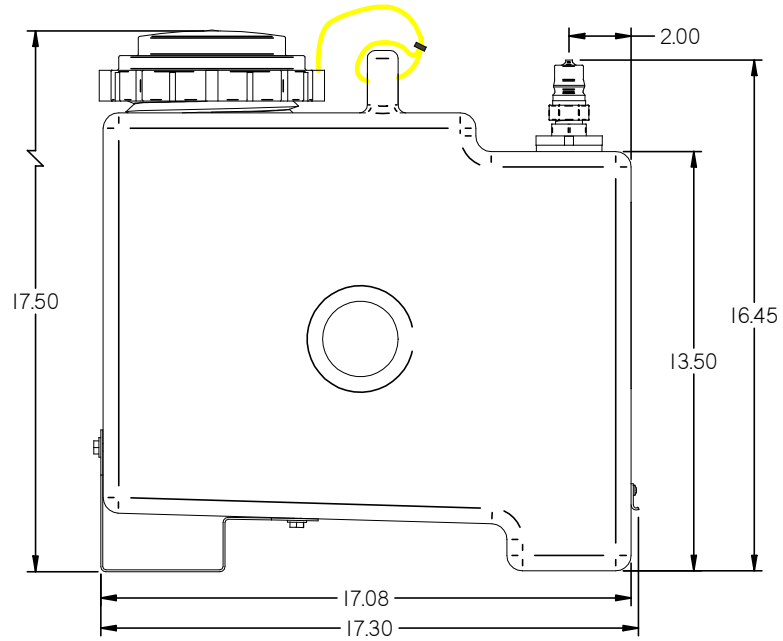

B

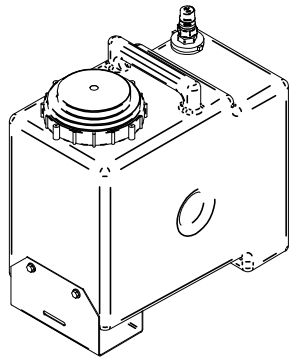
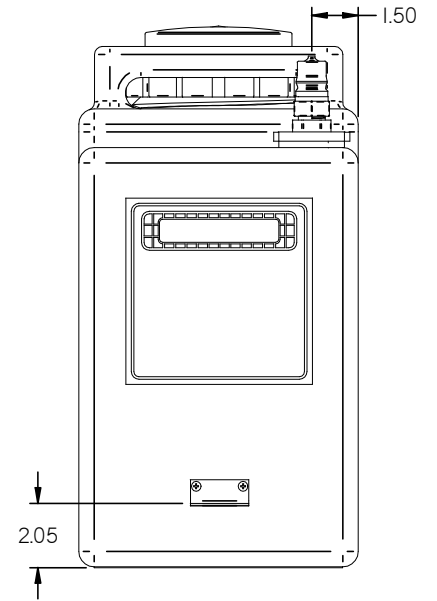

C

D



| | | | | | |
|------|----------|----------|--|----|---|
| | | | MATERIAL: | NA |  |
| | | | FINISH: | NA | |
| R5 | 8/31/98 | 98097-8 | PROJECTION: | | TITLE: TANK, 7.5GAL. .5" FITTING |
| R4 | 12/10/97 | 97318-10 | SCALE: UNITS: X INCH: 1/4 METRIC: X | | DRAWN BY: <i>Bryan Reiser</i> |
| R3 | 6/24/98 | UP DATED | UNLESS OTHERWISE SPECIFIED TOLERANCE: | | CHECKED BY: <i>Miss Irwin</i> |
| R2 | 6/2/97 | UP DATED | 0-1" +/- .1" = 10-60" +/- .1" = 3XX | | APPROVED BY: <i>Erica Saterius</i> |
| R1 | 7/11/91 | UP DATED | 1-5" +/- .25" = 60-120" +/- .2" = 1XX | | SHEET No: 2 of 2 |
| RO | 1/2/90 | RELEASED | 5-10" +/- .5" = 120" +/- .3" = 2 | | DWG No: C-160-0001 |
| REV. | DATE | NO. No | Midwest Technologies IL, LLC. Claims proprietary right in the material disclosed hereon. This document is not to be used in any way detrimental to the interest of Midwest Technologies IL, LLC. | | |