

CLAMP SIZE X OUTLET CONN.	TO CLAMP ON		OUTLET CONN. NPT (F) OR BSPT (F)	DIMENSIONS			NET WEIGHT	MAXIMUM OPERATING PRESSURE	MAX. REC. FLOW RATE @ MAX. PRESSURE	
	PIPE SIZE	OUTSIDE DIA. TUBING		APPROX. LENGTH & WIDTH	"A" DIM FOR SCREWS	"B" DIA. OF HOLE TO BE DRILLED				"c" BODY INLET DIA.
1/2 x 1/8	1/2"	13/16", 7/8" (20 - 22 mm)	1/8	1 7/8" x 1"	1 3/8"	9/32" (7.1 mm)	3/16" (4.8 mm)	.13 lbs. (0.06 kg)	250 PSI (17 bar)	3.5 GPM (13 l/min.)
1/2 x 1/4			1/4	(48 x 25.4 mm)	(35 mm)					
3/4 x 1/8	3/4"	1", 1 1/16" (25 - 27 mm)	1/8	2 1/8" x 1"	1 5/8"					
3/4 x 1/4			1/4	(54 x 25.4 mm)	(41.3 mm)					
1 x 1/8	1"	1 1/8", 1 1/4" & 1 3/8" (32 - 35 mm)	1/8	2 1/4" x 1"	1 3/4"					
1 x 1/4			1/4	(57 x 25.4 mm)	(44.4 mm)					

MATERIAL CODE: A = ZINC PLATED STEEL CLAMPS AND BOLTS WITH BRASS CONNECTOR BODY
 B = STAINLESS STEEL THROUGHOUT
 C = ZINC PLATED STEEL CLAMPS AND BOLTS WITH STAINLESS STEEL BODY

HOW TO ORDER: _____ 7521 _____ - _____ x _____
 THREAD MATERIAL CLAMP OUTLET
 TYPE CODE SIZE CONN.
 (BLANK = NPT)
 B = BSPT

EXAMPLES: 7521A-3/4 x 1/8 OR B7521A-3/4 x 1/4

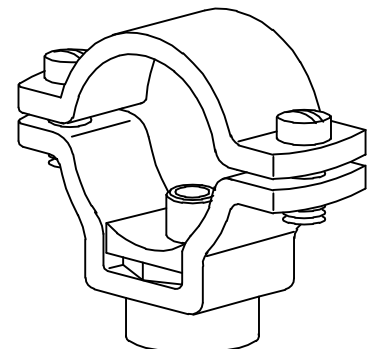

DESCRIPTION:
 NO. 7521----
 SPLIT-EYELET CONNECTORS



Spraying Systems Co.[®]

Spray Nozzles and Accessories
 P.O. Box 7900 - Wheaton, IL 60189-7900

Rev. No. 1

Ref.

Data Sheet No.

7521

SHEET OF