

DOCJET TIP NO.	LIQUID PRESSURE p.s.i.	CAPACITY G.P.M.	'L' FT.	GALLONS PER ACRE					
				3 M.P.H.	4 M.P.H.	5 M.P.H.	6 M.P.H.	8 M.P.H.	10 M.P.H.
DDOC-28	10	1.4	27	8.6	6.4	5.1	4.3	3.2	2.5
	15	1.7	32	8.8	6.6	5.3	4.4	3.3	2.6
	20	2.0	36	9.2	6.9	5.5	4.6	3.5	2.7
	30	2.4	38	10.4	7.8	6.3	5.2	3.9	3.1
	40	2.8	40	11.5	8.7	6.9	5.8	4.3	3.5
60	3.4	41	13.7	10.0	8.2	6.9	5.1	4.1	
DDOC-42	10	2.1	28	12.4	9.3	7.4	6.2	4.6	3.7
	15	2.6	33	12.9	9.6	7.7	6.4	4.8	3.9
	20	3.0	36	13.6	10.2	8.2	6.8	5.1	4.1
	30	3.6	38	15.8	11.9	9.5	7.9	5.9	4.7
	40	4.2	40	17.3	13.0	10.4	8.7	6.5	5.2
60	5.2	41	21	15.5	12.4	10.4	7.8	6.2	
DDOC-64	10	3.2	29	18.2	13.7	10.9	9.1	6.8	5.5
	15	3.9	34	19.0	14.3	11.4	9.5	7.2	5.7
	20	4.5	37	20	15.2	12.1	10.1	7.6	6.1
	30	5.6	39	24	17.6	14.1	11.8	8.8	7.1
	40	6.4	40	26	20	15.9	13.2	9.9	7.9
60	7.9	41	32	24	19.0	15.8	11.9	9.5	
DDOC-96	10	4.8	30	26	20	15.9	13.2	9.9	7.9
	15	5.9	34	29	21	17.2	14.3	10.7	8.6
	20	6.8	38	30	22	17.6	14.7	11.1	8.8
	30	8.3	39	35	26	21	17.6	13.2	10.6
	40	9.6	40	40	30	24	20	14.9	11.9
60	11.8	41	47	35	28	24	17.7	14.2	
DDOC-144	10	7.2	31	38	29	23	19.2	14.4	11.5
	15	8.8	35	42	31	25	21	15.6	12.5
	20	10.2	39	43	32	26	22	16.2	13.0
	30	12.5	40	51	38	31	26	19.3	15.4
	40	14.4	41	58	43	35	29	22	17.4
60	17.7	42	69	52	42	35	26	21	

U.S. AND FOREIGN PATENTS

TYPE DDOC--DOCJET TIP

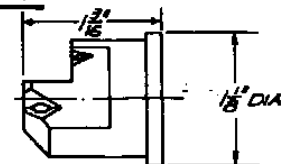

TYPE DDOC-DOCJET TIP

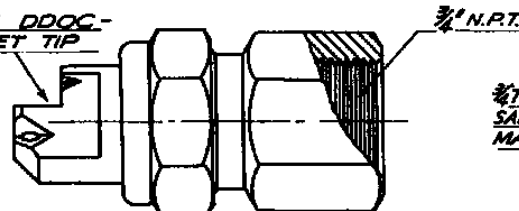

3/4 TEEJET NOZZLE IS THE SAME EXCEPT IT HAS A MALE 3/8 N.P.T. CONNECTION.

3/4 TEEJET NOZZLE WITH DOCJET TIP

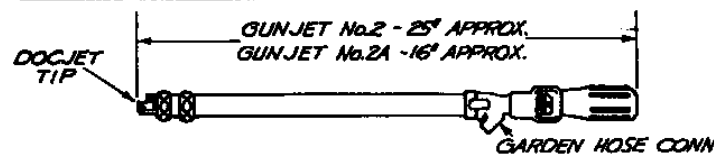

FOR DETAILS ON No. 2 GUNJETS SEE BULLETIN No. 65

NOTE: THE DDOC--DOCJET TIP CAN BE MADE TO SPRAY TO ONE SIDE ONLY BY USE OF #7927 SELECTOR PLUG. SEE DWG. 7712.

TABULATION IS BASED ON SPRAYING WATER AT TEMPERATURE OF 70°.

COVERAGES ARE BASED ON RIG BEING IN MOTION AT SPEEDS LISTED AND ON GUNJET SET TO ALLOW MAXIMUM FLOW THROUGH TIP.

G.P.M. = CAPACITY IN GALLONS PER MINUTE
M.P.H. = SPEED OF RIG IN MILES PER HOUR
P.S.I. = LIQUID PRESSURE IN LBS. PER SQ. INCH

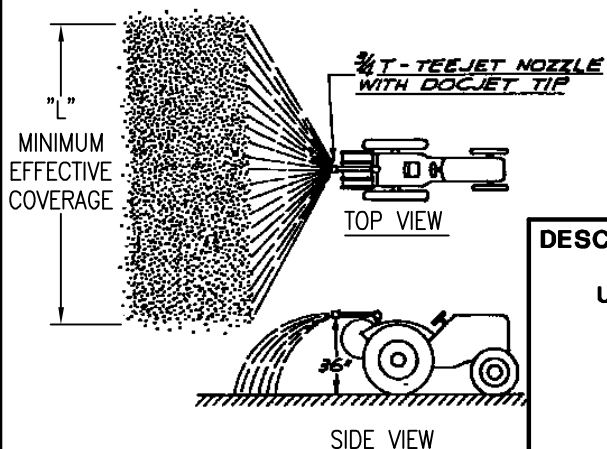

DESCRIPTION:

TYPE DDOC DOCJET TIP AS USED WITH 3/4 TEEJET NOZZLE OR GUNJET NO. 2



Spraying Systems Co.®

Spray Nozzles and Accessories
P.O. Box 7900 - Wheaton, Ill. 60189-7900

Rev. No.

Data Sheet No.

Ref.

7320

SHEET OF