

MODEL NO.	MAXIMUM ADJUSTMENT P.S.I.	CONNECTIONS		MATERIALS								
		INLET N.P.T. (M)	OUTLET N.P.T. (F)	BODY	GUIDE SEAT	INLET ADAPTER						
6815-1/2-50	50	1/2"	1/2"	BRASS	BRASS	BRASS						
6815-3/4-50		3/4"	3/4"									
6815-1/2-300	300	1/2"	1/2"									
6815-3/4-300		3/4"	3/4"									
6815-1/2-700	700	1/2"	1/2"									
6815-3/4-700		3/4"	3/4"									
6815-1/2 AL-50	50	1/2"	1/2"	ALUMINUM	ALUMINUM	ALUMINUM						
6815-3/4 AL-50		3/4"	3/4"									
6815-1/2 AL-300	300	1/2"	1/2"									
6815-3/4 AL-300		3/4"	3/4"									
6815-1/2 AL-700	700	1/2"	1/2"									
6815-3/4 AL-700		3/4"	3/4"									
6815-1/2 HSS-300	300	1/2"	1/2"	BRASS	BRASS WITH HARDENED STAINLESS STEEL SEAT	BRASS WITH HARDENED STAINLESS STEEL SEAT						
6815-3/4 HSS-300		3/4"	3/4"									
6815-1/2 HSS-700	700	1/2"	1/2"									
6815-3/4 HSS-700		3/4"	3/4"									
6815-1/2 HSS-1200	1200	1/2"	1/2"				ALUMINUM	HARDENED STAINLESS STL.	HARDENED STAINLESS STL.			
6815-3/4 HSS-1200		3/4"	3/4"									
6815-AL-1/2 HSS-300	300	1/2"	1/2"	ALUMINUM WITH HARDENED STAINLESS STEEL SEAT	HARDENED STAINLESS STL.	ALUMINUM WITH HARDENED STAINLESS STEEL SEAT						
6815-AL-3/4 HSS-300		3/4"	3/4"									
6815-AL-1/2 HSS-700	700	1/2"	1/2"							HARDENED STAINLESS STL.	HARDENED STAINLESS STL.	HARDENED STAINLESS STL.
6815-AL-3/4 HSS-700		3/4"	3/4"									
6815-AL-1/2 HSS-1200	1200	1/2"	1/2"				ALUMINUM	HARDENED STAINLESS STL.	HARDENED STAINLESS STL.			
6815-AL-3/4 HSS-1200		3/4"	3/4"									

MODELS 6815-1/2 & 3/4 for pressures up to 1200 p.s.i.

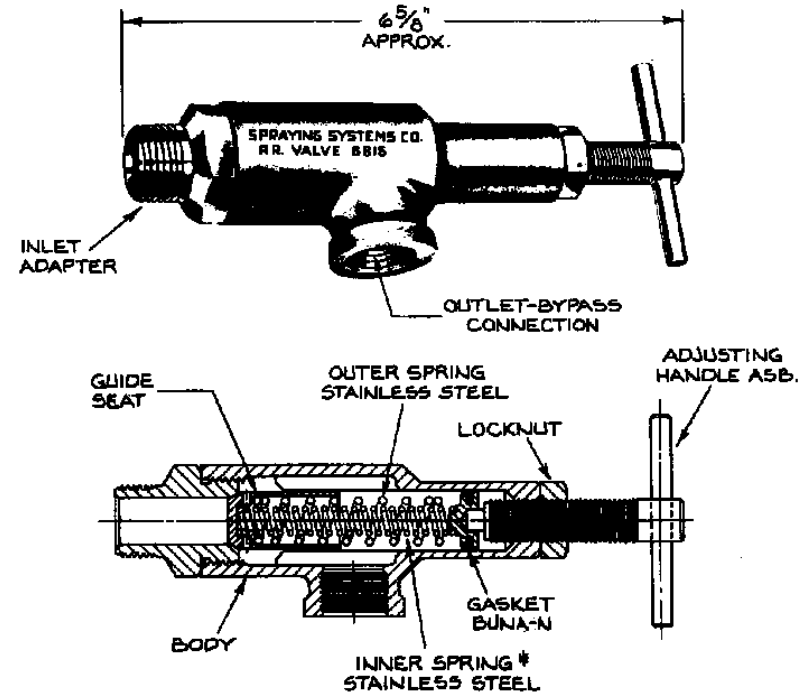

*INNER SPRING USED ONLY ON MODEL 6815-300.
FOR ADDITIONAL INFORMATION ON TYPE 6815-1/2 & 3/4 PRESSURE RELIEF VALVES, SEE BULLETIN 191.

MODEL NO.	MAXIMUM FLOW IN G.P.M. THROUGH VALVE AT VARIOUS PRESSURES IN P.S.I. (WITH VALVE FULL OPEN)											
	10 PSI	15 PSI	20 PSI	25 PSI	30 PSI	35 PSI	40 PSI	50 PSI	60 PSI	70 PSI	80 PSI	100 PSI
6815-1/2 & 3/4-300	18	23	26	29	32	34	36	40	44	47	50	56
6815-1/2 & 3/4-700	10	12	14	15	16	17	18	19	20	21	22	23

DESCRIPTION:
TYPE 6815-
PRESSURE RELIEF VALVES



Spraying Systems Co.[®]

Spray Nozzles and Accessories
P.O. Box 7900 - Wheaton, Ill. 60189-7900

Rev. No. 1

Data Sheet No.

Ref.

6815

SHEET OF