

50-SERIES:

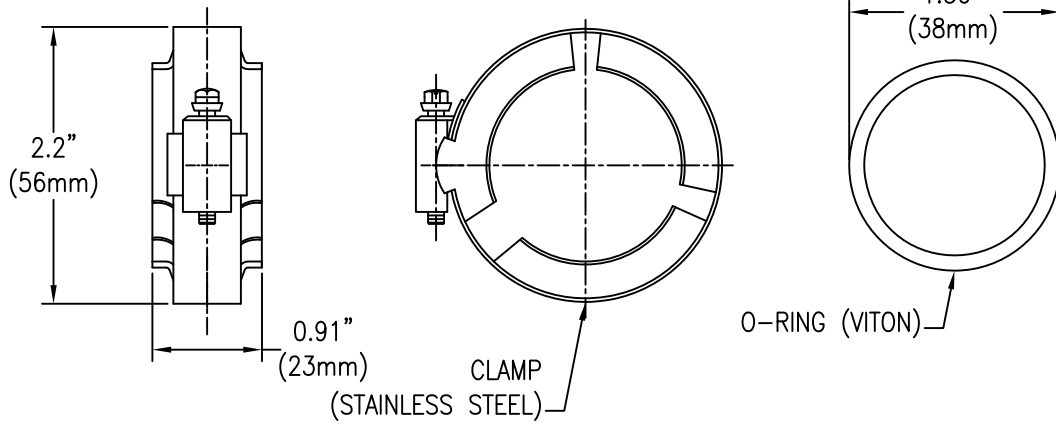

75-SERIES:

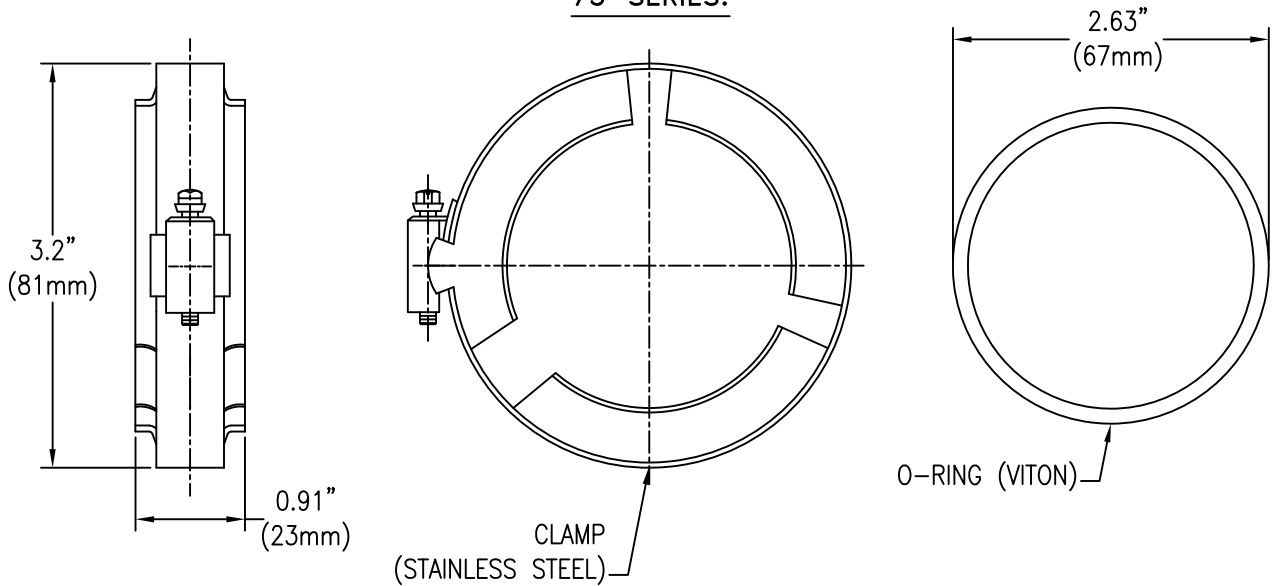

FEATURES:

- STAINLESS STEEL CLAMP CONSTRUCTION WITH VITON® O-RINGS
- WORM DRIVE SCREW WITH 5/16" (8mm) HEX DRIVE AND SCREWDRIVER SLOT
- FOR USE WITH TEEJET® 50- AND 75-SERIES FLANGE FITTINGS
- RECOMMENDED INSTALLATION TORQUE: 40 IN-LB (4.5 N-m)

HOW TO ORDER:

PART DESCRIPTION	50-SERIES PART NO.	75-SERIES PART NO.
CLAMP & O-RING	55245-50	55245-75
CLAMP	CP55246-50-SS	CP55246-75-SS
O-RING	CP7717-2-222-VI	CP7717-2-229-VI

VITON® IS A TRADEMARK OF DUPONT PERFORMANCE ELASTOMERS

DESCRIPTION:

**55245-50 & 55245-75
50- & 75-SERIES
STAINLESS STEEL
FLANGE CONNECTORS**



Spraying Systems Co.®

Spray Nozzles and Accessories
P.O. Box 7900 - Wheaton, Il. 60189-7900

Rev. No.

Ref.

DATA SHEET

55245

SHEET OF