

WIRING DIAGRAM (POSITIVELY SWITCHED)

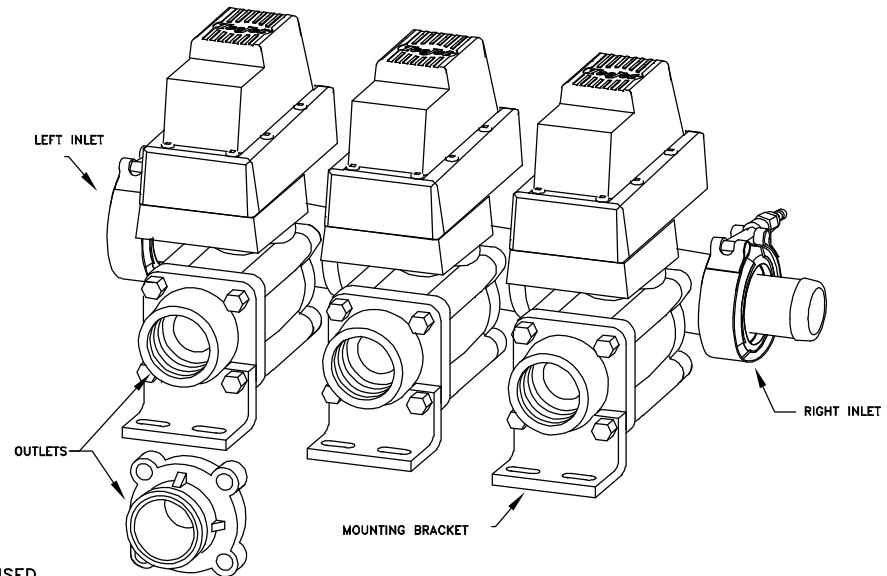

FEATURES:

- INLETS CAN BE EQUIPPED WITH ANY 75-SERIES FLANGE FITTING INCLUDING: THREADED FITTINGS, HOSE BARBS, BLANKS, GAUGE PORTS, AND COUPLINGS.
- AVAILABLE OUTLETS INCLUDE: 1-1/4" AND 1-1/2" THREADED ENDCAPS (NPT OR BSPT) AND 50 SERIES FLANGED ENDCAP.
- FLANGE TYPE OUTLETS CAN BE EQUIPPED WITH ANY 50 SERIES FLANGE FITTINGS. SEE DATA SHEETS FLANGE-1 & FLANGE-2 FOR INLET AND OUTLET FLANGE FITTINGS.
- MAXIMUM PRESSURE RATING: 150 PSI [10 bar]
- RESPONSE TIME FROM CLOSED TO OPEN 3/4 SECOND.
- CURRENT DURING OPENING AND CLOSING: 2.5 AMPS NOMINAL.
- FLOW RATE PER VALVE: 64 GPM @ 5 PSI [322 LPM @ .3 BAR] PRESSURE DROP.
- SEALED MOTOR ASSEMBLY WITHSTANDS PRESSURE WASHING.
- AUTOMATIC RESETABLE FUSE. (DISCONNECT POWER SUPPLY FOR 20 SECONDS TO RESET)
- WETTED PARTS MADE OF CORROSION RESISTANT MATERIAL: GLASS-REINFORCED POLYPROPYLENE, TEFLON, VITON AND STAINLESS STEEL.
- FOR JACKETED CABLE: RED LEAD IS (+) BATTERY, BLACK LEAD IS (-) GROUND, AND WHITE LEAD IS SIGNAL.

- AVAILABLE WITH TYPE 43650-A DIN CONNECTOR OR JACKETED CABLE.
- DIN VERSIONS AVAILABLE WITH DIN CABLE IN .5, 1.5, 3, 5, & 6 METER LENGTHS. ALSO AVAILABLE WITH DIN CONECTOR LESS CABLE.
- JACKETED CABLE VERSIONS AVAILABLE IN .5, 1.5, 3, 4, 5, & 6 METER LENGTHS. (NOT SHOWN)
- UNIVERSAL WIRING FOR BOTH POSITIVE AND NEGATIVE SWITCHED SYSTEMS. SEE DATA SHEET 45218 FOR NEGATIVELY SWITCHED OPERATION.

CONTACT YOUR LOCAL TEEJET REGIONAL SALES OFFICE FOR ORDERING INFORMATION
SEE PARTS LIST PL480 FOR COMPONENT PART NUMBERS

DESCRIPTION:
480
DIRECTOVALVE® MANIFOLD
ASSEMBLY
(NPT & BSPT CONN.)



Spraying Systems Co.®
Spray Nozzles and Accessories
P.O. Box 7900 - Wheaton, IL 60189-7900

Rev. No. 2

Data Sheet No.

Ref.

480

SHEET OF