

The Trigger TEEJET offers the flexibility of the TEEJET nozzle plus a positive action hand operated shut-off valve. The Trigger TEEJET is light in weight and is designed for comfort and ease in operation.

Note the following features:

1. The Trigger TEEJET can be supplied with standard flat spray tips (Dwg. 2851), hollow cone tips (Dwg. 4411), full cone tips (Dwg. 4517), disc-type tips (Dwg. 4498), as well as the MultiTEEJET tip assembly (Dwg. 4667).
2. Standard TEEJET strainer assembly prevents clogging of orifice.
3. Replaceable valve seat. Plunger assembly is sold as a unit and can be installed in a minute's time.
4. 1/4" tapered pipe thread.
5. 1/8" pipe and bushing assembly... the customer's rubber hose slipped over the extending pipe will act as a handle.
6. Trigger lock... permits locking valve in open position for continuous flow of liquid. Easily disengaged by slight pressure on trigger.
7. Trigger... designed to correct proportions for ease and comfort in operation.

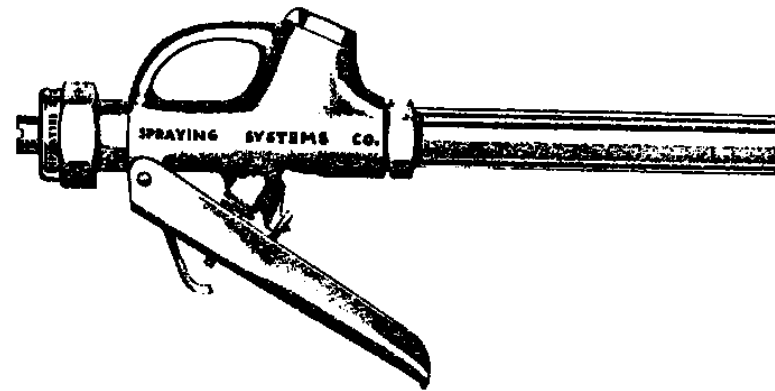

VARIOUS EXTENSIONS THAT CAN BE MADE USING STANDARD TEEJET NOZZLES AND FITTINGS.

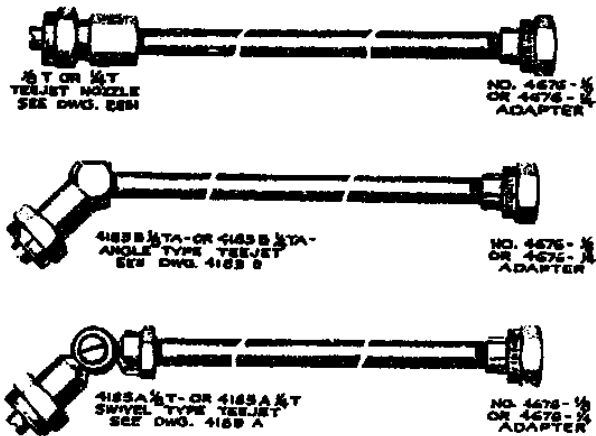

NOTE: ADAPTER 4676-1/2 HAS A 1/2" FEMALE PIPE CONN.
ADAPTER 4676-1/4 HAS A 1/4" FEMALE PIPE CONN.

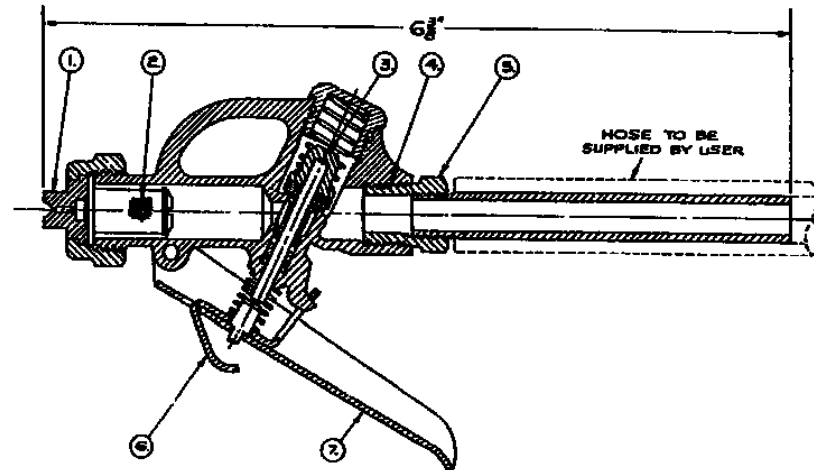

DESCRIPTION:
TRIGGER TEEJET



Spraying Systems Co.

Spray Nozzles and Accessories
P.O. Box 7900 - Wheaton, Ill. 60189-7900

Rev. No.

Data Sheet No.

4675

Ref.

SHEET OF