

NOZZLE NO.	LIQUID PRESSURE IN P.S.I.	CAPACITY IN G.P.M.	SPRAY HEIGHT "H" = 24"					SPRAY HEIGHT "H" = 36"					SPRAY HEIGHT "H" = 48"					SPRAY HEIGHT "H" = 60"				
			"L" IN FEET	GALLONS PER ACRE			"L" IN FEET	GALLONS PER ACRE			"L" IN FEET	GALLONS PER ACRE			"L" IN FEET	GALLONS PER ACRE						
				3 MPH	4 MPH	5 MPH		3 MPH	4 MPH	5 MPH		3 MPH	4 MPH	5 MPH		3 MPH	4 MPH	5 MPH				
4629-3/4TOC18	10	.50	13-1/2	6.1	4.6	3.7	14	5.9	4.4	3.5	14-1/2	6.7	4.9	3.4	15	5.5	4.1	3.3				
	15	.61	15	6.7	5.1	4.0	15-1/2	6.5	4.9	3.9	16	6.3	4.7	3.8	16-1/2	6.1	4.6	3.7				
	20	.71	16-1/2	7.1	5.3	4.2	17	6.9	5.1	4.1	17-1/2	6.7	5.0	4.0	18	6.5	4.9	3.9				
	30	.87	17-1/2	8.2	6.1	4.9	18	7.9	6.0	4.8	18-1/2	7.7	5.8	4.6	19	7.5	5.6	4.5				
	40	1.0	18	9.2	6.9	5.5	18-1/2	8.9	6.7	5.3	19	8.7	6.5	5.2	19-1/2	8.5	6.3	5.1				
	60	1.2	18	11.2	8.4	6.7	18-1/2	10.9	8.2	6.5	19	10.6	8.0	6.4	19-1/2	10.4	7.8	6.2				
4629-3/4TOC20	10	1.0	16-1/2	10.1	7.6	6.1	17-1/2	9.5	7.1	5.7	18	9.3	6.9	5.6	18-1/2	9.0	6.8	5.4				
	15	1.2	20	10.3	7.7	6.2	20-1/2	9.7	7.3	5.8	21	9.5	7.1	5.7	21-1/2	9.3	7.0	5.6				
	20	1.4	22	10.6	7.9	6.4	22-1/2	10.4	7.8	6.2	23	10.1	7.6	6.1	23-1/2	9.9	7.4	6.0				
	30	1.7	23	12.3	9.2	7.4	23-1/2	12.1	9.0	7.2	24	11.8	8.8	7.1	24-1/2	11.6	8.7	6.9				
	40	2.0	24	13.9	10.4	8.3	24-1/2	13.6	10.2	8.2	25	13.3	10.0	8.0	25-1/2	13.1	9.8	7.8				
	60	2.4	24	16.7	12.5	10.0	24-1/2	16.3	12.2	9.8	25	16.0	12.0	9.6	25-1/2	15.7	11.7	9.4				
4629-3/4TOC30	10	1.5	18	13.8	10.3	8.2	18-1/2	13.4	10.0	8.0	19	13.0	9.8	7.8	19-1/2	12.7	9.5	7.6				
	15	1.8	21	14.4	10.8	8.7	21-1/2	14.1	10.6	8.5	22	13.8	10.3	8.3	22-1/2	13.5	10.1	8.1				
	20	2.1	23	15.1	11.3	9.0	23-1/2	14.7	11.1	8.8	24	14.4	10.8	8.7	24-1/2	14.1	10.6	8.5				
	30	2.6	24-1/2	17.5	13.1	10.8	25	17.2	12.9	10.3	25-1/2	16.8	12.7	10.1	26	16.5	12.4	9.9				
	40	3.0	25-1/2	19.4	14.6	11.6	26	19.0	14.1	11.4	26-1/2	18.7	14.0	11.2	27	18.3	13.8	11.0				
	60	3.7	25-1/2	23.9	18.0	14.4	26	23.5	17.8	14.1	26-1/2	23.0	17.3	13.6	27	22.4	17.0	13.6				
4629-3/4TOC40	10	2.0	19	17.5	13.2	10.5	19-1/2	17.1	12.8	10.3	20	16.7	12.5	10.0	20-1/2	16.2	12.2	9.8				
	15	2.5	22	19.0	14.2	11.4	22-1/2	18.5	13.9	11.1	23	18.1	13.6	10.9	23-1/2	17.7	13.3	10.6				
	20	2.8	24	19.4	14.6	11.7	24-1/2	19.0	14.3	11.4	25	18.7	14.0	11.2	25-1/2	18.3	13.7	10.9				
	30	3.5	25-1/2	22.9	17.1	13.7	26	22.4	16.8	13.5	26-1/2	22.0	16.5	13.2	27	20.8	15.6	12.8				
	40	4.0	26-1/2	25.2	18.9	15.1	27	24.7	18.5	14.8	27-1/2	24.2	18.2	14.5	28	23.8	17.9	14.3				
	60	4.9	26-1/2	30.9	23.1	18.5	27	30.2	22.7	18.1	27-1/2	29.7	22.3	17.8	28	29.2	23.9	17.5				
4629-3/4TOC50	10	3.0	20	24.8	18.6	14.9	20-1/2	24.1	18.1	14.5	21	23.6	17.7	14.1	21-1/2	23.0	17.3	13.8				
	15	3.7	23	26.5	19.9	15.9	23-1/2	26.0	19.5	15.6	24	25.4	19.1	15.3	24-1/2	24.9	18.7	14.9				
	20	4.2	25	27.7	20.8	16.6	25-1/2	27.2	20.4	16.3	26	26.7	20.0	16.0	26-1/2	26.1	19.6	15.7				
	30	5.2	27	31.8	23.8	19.1	27-1/2	31.2	23.4	18.7	28	30.6	23.0	18.4	28-1/2	30.1	22.6	18.1				
	40	6.0	28	35.4	26.5	21.2	28-1/2	34.7	26.1	20.8	29	34.1	25.6	20.5	29-1/2	33.6	25.2	20.1				
	60	7.4	28	43.6	32.7	26.2	28-1/2	42.8	32.1	25.7	29	42.1	31.6	25.3	29-1/2	41.4	31.0	24.8				
4629-3/4TOC80	10	4.0	21	31.8	23.8	19.1	21-1/2	31.0	23.3	18.6	22	30.3	22.7	18.2	22-1/2	29.6	22.2	17.8				
	15	5.0	24	34.0	25.5	20.4	24-1/2	33.4	25.0	20.0	25	32.6	24.5	19.6	25-1/2	32.0	24.0	18.2				
	20	5.6	26	35.9	26.9	21.6	26-1/2	35.2	26.4	21.1	27	34.6	26.0	20.8	27-1/2	33.9	25.4	20.4				
	30	7.0	28-1/2	39.8	29.8	23.9	29	39.0	29.3	23.4	29-1/2	38.4	28.8	23.0	30	37.8	28.4	22.7				
	40	8.0	29-1/2	45.2	33.9	27.2	30	44.4	33.3	26.6	30-1/2	43.7	32.8	25.2	31	43.0	32.2	25.8				
	60	9.8	29-1/2	54.8	41.1	32.9	30	53.9	40.4	32.4	30-1/2	53.0	39.6	31.8	31	52.2	39.1	31.3				

TABULATIONS ABOVE ARE BASED ON STATIONARY NOZZLE AND ON WATER AT TEMPERATURE OF 70° F.

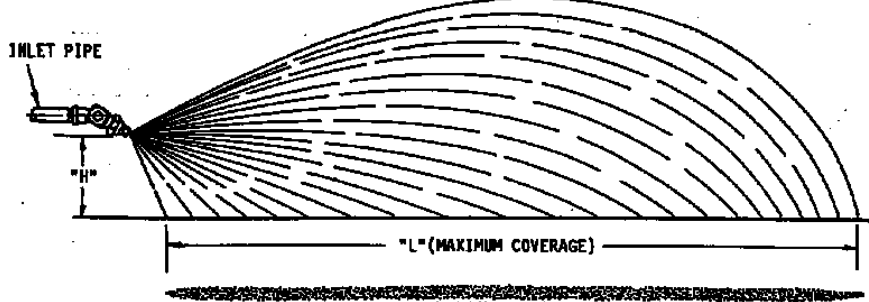

FLAT SPRAY PATTERN

FOR MAXIMUM COVERAGE NOZZLE IS SET TO HAVE THE UPPER LEADING EDGE OF THE SPRAY MAKE A 30° ANGLE WITH THE HORIZONTAL.

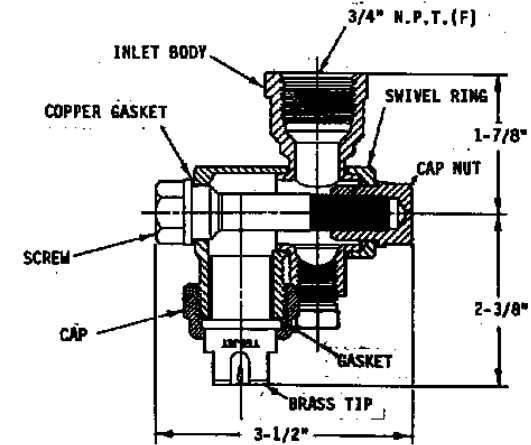
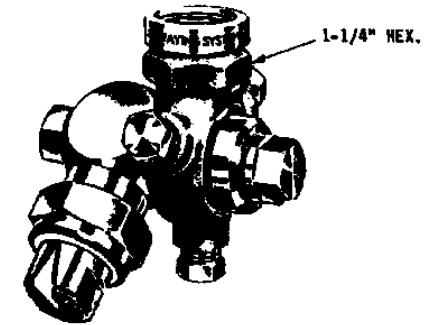

DESCRIPTION: NO. 4629-3/4T OC-- SINGLE SWIVEL NOZZLE		 Spraying Systems Co. Spray Nozzles and Accessories P.O. Box 7900 - Wheaton, Ill. 60189-7900
Rev. No. 1	Data Sheet No. 4629	
Ref.	SHEET OF	