

# DG TwinJet®

DRIFT GUARD TWINJET TWIN FLAT SPRAY TIP WITH **VisiFlo®** COLOR CODING

### DROPLET SIZE CATEGORIES

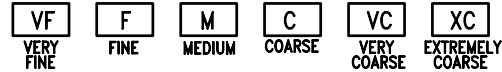

Droplet size classifications are based on BPCP specifications and in accordance with ASAE Standard S-572 at the date of printing. Classifications are subject to change.

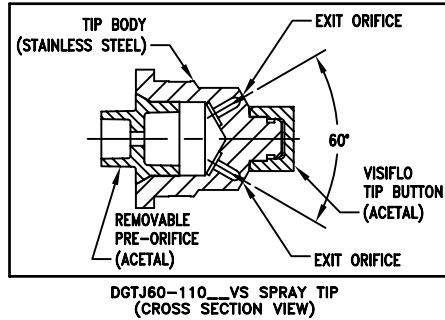

#### FEATURES:

- STAINLESS STEEL CONSTRUCTION WITH VISIFLO COLOR CODING FOR EXCELLENT CHEMICAL AND WEAR RESISTANCE.
- REMOVABLE PRE-ORIFICE FOR FAST AND EASY CLEANING.
- PARTICULARLY WELL SUITED FOR FUNGICIDE APPLICATION.
- TIP PRODUCES DUAL TAPERED EDGE FLAT SPRAY PATTERNS FOR UNIFORM COVERAGE IN BROADCAST SPRAYING.
- DUAL, ANGLED SPRAY PATTERNS HELP TO BETTER PENETRATE CROP CANOPY AND PROVIDE THOROUGH LEAF COVERAGE.
- OFFERS LARGER DROPLET SIZE AND IMPROVED DRIFT CONTROL AS COMPARED TO A STANDARD TWINJET SPRAY TIP OF EQUAL CAPACITY.
- AUTOMATIC ALIGNMENT WITH USE OF CP25597-\*--NY (TWINJET) CAP.
- SUGGESTED SPRAY PRESSURE RANGE: 2-4 BAR.

#### TYPICAL APPLICATIONS:

- EXCELLENT FOR POST-EMERGE CONTACT HERBICIDE APPLICATIONS—MINIMUM SPRAY PRESSURE OF 2 BAR.
- EXCELLENT FOR FUNGICIDE APPLICATIONS—MINIMUM SPRAY PRESSURE OF 2 BAR.

SPRAY ANGLE	OPTIMUM SPRAY HEIGHT	
	50cm SPACING	75cm SPACING
110°	50 cm	75 cm

Tip Color VisiFlo	Tip No. (Strainer Screen Size)	Liquid Pressure (bar)	Capacity 1 Nozzle (l/min)	Liters Per Hectare 50 cm Spacing*										DROPLET SIZE CLASSI- FICATION																																																																																																																																																																																																																																																																																																																																																																																																															
				4 km/h	5 km/h	6 km/h	8 km/h	10 km/h	12 km/h	16 km/h	20 km/h	25 km/h	30 km/h																																																																																																																																																																																																																																																																																																																																																																																																																
GREEN	DGTJ60-110015VS (100 Mesh)	2.0	0.48	144	115	96.0	72.0	57.6	48.0	36.0	28.8	23.0	19.2	F																																																																																																																																																																																																																																																																																																																																																																																																															
		2.5	0.54	162	130	108	81.0	64.8	54.0	40.5	32.4	25.9	21.6	F																																																																																																																																																																																																																																																																																																																																																																																																															
		3.0	0.59	177	142	118	88.5	70.8	59.0	44.3	35.4	28.3	23.6	F																																																																																																																																																																																																																																																																																																																																																																																																															
		3.5	0.64	192	154	128	96.0	76.8	64.0	48.0	38.4	30.7	25.6	F																																																																																																																																																																																																																																																																																																																																																																																																															
		4.0	0.68	204	163	136	102	81.6	68.0	51.0	40.8	32.6	27.2	F																																																																																																																																																																																																																																																																																																																																																																																																															
5.0	0.76	228	182	152	114	91.2	76.0	57.0	45.6	36.5	30.4	F	YELLOW	DGTJ60-11002VS (100 Mesh)	2.0	0.65	195	156	130	97.5	78.0	65.0	48.8	39.0	31.2	26.0	M	2.5	0.72	216	173	144	108	86.4	72.0	54.0	43.2	34.6	28.8	M	3.0	0.79	237	190	158	119	94.8	79.0	59.3	47.4	37.9	31.6	F	3.5	0.85	255	204	170	128	102	85.0	63.8	51.0	40.8	34.0	F	4.0	0.91	273	218	182	137	109	91.0	68.3	54.6	43.7	36.4	F	5.0	1.02	306	245	204	153	122	102	76.5	61.2	49.0	40.8	F	BLUE	DGTJ60-11003VS (100 Mesh)	2.0	0.96	288	230	192	144	115	96.0	72.0	57.6	46.1	38.4	C	2.5	1.08	324	259	216	162	130	108	81.0	64.8	51.8	43.2	M	3.0	1.18	354	283	236	177	142	118	88.5	70.8	56.6	47.2	M	3.5	1.27	381	305	254	191	152	127	95.3	76.2	61.0	50.8	M	4.0	1.36	408	326	272	204	163	136	102	81.6	65.3	54.4	M	5.0	1.52	456	365	304	228	182	152	122	114	91.2	73.0	60.8	M	RED	DGTJ60-11004VS (50 Mesh)	2.0	1.29	387	310	258	194	155	129	96.8	77.4	61.9	51.6	C	2.5	1.44	432	346	288	216	173	144	108	86.4	69.1	57.6	C	3.0	1.58	474	379	316	237	190	158	119	94.8	75.8	63.2	C	3.5	1.71	513	410	342	257	205	171	128	103	82.1	68.4	C	4.0	1.82	546	437	364	273	218	182	137	109	87.4	72.8	C	5.0	2.04	612	490	408	306	245	204	153	122	97.9	81.6	M	GRAY	DGTJ60-11006VS (50 Mesh)	2.0	1.94	582	466	388	291	233	194	146	116	93.1	77.6	C	2.5	2.16	648	518	432	324	259	216	162	130	104	86.4	C	3.0	2.37	711	569	474	356	284	237	178	142	114	94.8	C	3.5	2.56	768	614	512	384	307	256	192	154	123	102	C	4.0	2.74	822	658	548	411	329	274	206	164	132	110	C	5.0	3.06	918	734	612	459	367	306	230	184	147	122	M	WHITE	DGTJ60-11008VS (50 Mesh)	2.0	2.58	774	619	516	387	310	258	194	155	124	103	C	2.5	2.88	864	691	576	432	346	288	216	173	138	115	C	3.0	3.16	948	758	632	474	379	316	237	190	152	126	C	3.5	3.41	1023	818	682	512	409	341	256	205	164	136	C	4.0	3.65	1095	876	730	548	438	365	274	219	175	146	C	5.0	4.08	1224	979	816	612	490	408	306	245	196	163	C
YELLOW	DGTJ60-11002VS (100 Mesh)	2.0	0.65	195	156	130	97.5	78.0	65.0	48.8	39.0	31.2			26.0	M																																																																																																																																																																																																																																																																																																																																																																																																													
		2.5	0.72	216	173	144	108	86.4	72.0	54.0	43.2	34.6			28.8	M																																																																																																																																																																																																																																																																																																																																																																																																													
		3.0	0.79	237	190	158	119	94.8	79.0	59.3	47.4	37.9			31.6	F																																																																																																																																																																																																																																																																																																																																																																																																													
		3.5	0.85	255	204	170	128	102	85.0	63.8	51.0	40.8			34.0	F																																																																																																																																																																																																																																																																																																																																																																																																													
		4.0	0.91	273	218	182	137	109	91.0	68.3	54.6	43.7	36.4	F																																																																																																																																																																																																																																																																																																																																																																																																															
5.0	1.02	306	245	204	153	122	102	76.5	61.2	49.0	40.8	F	BLUE	DGTJ60-11003VS (100 Mesh)	2.0	0.96	288	230	192	144	115	96.0	72.0	57.6	46.1	38.4	C	2.5	1.08	324	259	216	162	130	108	81.0	64.8	51.8	43.2	M	3.0	1.18	354	283	236	177	142	118	88.5	70.8	56.6	47.2	M	3.5	1.27	381	305	254	191	152	127	95.3	76.2	61.0	50.8	M	4.0	1.36	408	326	272	204	163	136	102	81.6	65.3	54.4	M	5.0	1.52	456	365	304	228	182	152	122	114	91.2	73.0	60.8	M	RED	DGTJ60-11004VS (50 Mesh)	2.0	1.29	387	310	258	194	155	129	96.8	77.4	61.9	51.6	C	2.5	1.44	432	346	288	216	173	144	108	86.4	69.1	57.6	C	3.0	1.58	474	379	316	237	190	158	119	94.8	75.8	63.2	C	3.5	1.71	513	410	342	257	205	171	128	103	82.1	68.4	C	4.0	1.82	546	437	364	273	218	182	137	109	87.4	72.8	C	5.0	2.04	612	490	408	306	245	204	153	122	97.9	81.6	M	GRAY	DGTJ60-11006VS (50 Mesh)	2.0	1.94	582	466	388	291	233	194	146	116	93.1	77.6	C	2.5	2.16	648	518	432	324	259	216	162	130	104	86.4	C	3.0	2.37	711	569	474	356	284	237	178	142	114	94.8	C	3.5	2.56	768	614	512	384	307	256	192	154	123	102	C	4.0	2.74	822	658	548	411	329	274	206	164	132	110	C	5.0	3.06	918	734	612	459	367	306	230	184	147	122	M	WHITE	DGTJ60-11008VS (50 Mesh)	2.0	2.58	774	619	516	387	310	258	194	155	124	103	C	2.5	2.88	864	691	576	432	346	288	216	173	138	115	C	3.0	3.16	948	758	632	474	379	316	237	190	152	126	C	3.5	3.41	1023	818	682	512	409	341	256	205	164	136	C	4.0	3.65	1095	876	730	548	438	365	274	219	175	146	C	5.0	4.08	1224	979	816	612	490	408	306	245	196	163	C																																																																																
BLUE	DGTJ60-11003VS (100 Mesh)	2.0	0.96	288	230	192	144	115	96.0	72.0	57.6	46.1			38.4	C																																																																																																																																																																																																																																																																																																																																																																																																													
		2.5	1.08	324	259	216	162	130	108	81.0	64.8	51.8			43.2	M																																																																																																																																																																																																																																																																																																																																																																																																													
		3.0	1.18	354	283	236	177	142	118	88.5	70.8	56.6			47.2	M																																																																																																																																																																																																																																																																																																																																																																																																													
		3.5	1.27	381	305	254	191	152	127	95.3	76.2	61.0			50.8	M																																																																																																																																																																																																																																																																																																																																																																																																													
		4.0	1.36	408	326	272	204	163	136	102	81.6	65.3	54.4	M																																																																																																																																																																																																																																																																																																																																																																																																															
5.0	1.52	456	365	304	228	182	152	122	114	91.2	73.0	60.8	M	RED	DGTJ60-11004VS (50 Mesh)	2.0	1.29	387	310	258	194	155	129	96.8	77.4	61.9	51.6	C	2.5	1.44	432	346	288	216	173	144	108	86.4	69.1	57.6	C	3.0	1.58	474	379	316	237	190	158	119	94.8	75.8	63.2	C	3.5	1.71	513	410	342	257	205	171	128	103	82.1	68.4	C	4.0	1.82	546	437	364	273	218	182	137	109	87.4	72.8	C	5.0	2.04	612	490	408	306	245	204	153	122	97.9	81.6	M	GRAY	DGTJ60-11006VS (50 Mesh)	2.0	1.94	582	466	388	291	233	194	146	116	93.1	77.6	C	2.5	2.16	648	518	432	324	259	216	162	130	104	86.4	C	3.0	2.37	711	569	474	356	284	237	178	142	114	94.8	C	3.5	2.56	768	614	512	384	307	256	192	154	123	102	C	4.0	2.74	822	658	548	411	329	274	206	164	132	110	C	5.0	3.06	918	734	612	459	367	306	230	184	147	122	M	WHITE	DGTJ60-11008VS (50 Mesh)	2.0	2.58	774	619	516	387	310	258	194	155	124	103	C	2.5	2.88	864	691	576	432	346	288	216	173	138	115	C	3.0	3.16	948	758	632	474	379	316	237	190	152	126	C	3.5	3.41	1023	818	682	512	409	341	256	205	164	136	C	4.0	3.65	1095	876	730	548	438	365	274	219	175	146	C	5.0	4.08	1224	979	816	612	490	408	306	245	196	163	C																																																																																																																																																																
RED	DGTJ60-11004VS (50 Mesh)	2.0	1.29	387	310	258	194	155	129	96.8	77.4	61.9	51.6			C																																																																																																																																																																																																																																																																																																																																																																																																													
		2.5	1.44	432	346	288	216	173	144	108	86.4	69.1	57.6			C																																																																																																																																																																																																																																																																																																																																																																																																													
		3.0	1.58	474	379	316	237	190	158	119	94.8	75.8	63.2			C																																																																																																																																																																																																																																																																																																																																																																																																													
		3.5	1.71	513	410	342	257	205	171	128	103	82.1	68.4			C																																																																																																																																																																																																																																																																																																																																																																																																													
		4.0	1.82	546	437	364	273	218	182	137	109	87.4	72.8	C																																																																																																																																																																																																																																																																																																																																																																																																															
5.0	2.04	612	490	408	306	245	204	153	122	97.9	81.6	M	GRAY	DGTJ60-11006VS (50 Mesh)	2.0	1.94	582	466	388	291	233	194	146	116	93.1	77.6	C	2.5	2.16	648	518	432	324	259	216	162	130	104	86.4	C	3.0	2.37	711	569	474	356	284	237	178	142	114	94.8	C	3.5	2.56	768	614	512	384	307	256	192	154	123	102	C	4.0	2.74	822	658	548	411	329	274	206	164	132	110	C	5.0	3.06	918	734	612	459	367	306	230	184	147	122	M	WHITE	DGTJ60-11008VS (50 Mesh)	2.0	2.58	774	619	516	387	310	258	194	155	124	103	C	2.5	2.88	864	691	576	432	346	288	216	173	138	115	C	3.0	3.16	948	758	632	474	379	316	237	190	152	126	C	3.5	3.41	1023	818	682	512	409	341	256	205	164	136	C	4.0	3.65	1095	876	730	548	438	365	274	219	175	146	C	5.0	4.08	1224	979	816	612	490	408	306	245	196	163	C																																																																																																																																																																																																																																																	
GRAY	DGTJ60-11006VS (50 Mesh)	2.0	1.94	582	466	388	291	233	194	146	116	93.1			77.6	C																																																																																																																																																																																																																																																																																																																																																																																																													
		2.5	2.16	648	518	432	324	259	216	162	130	104			86.4	C																																																																																																																																																																																																																																																																																																																																																																																																													
		3.0	2.37	711	569	474	356	284	237	178	142	114			94.8	C																																																																																																																																																																																																																																																																																																																																																																																																													
		3.5	2.56	768	614	512	384	307	256	192	154	123			102	C																																																																																																																																																																																																																																																																																																																																																																																																													
		4.0	2.74	822	658	548	411	329	274	206	164	132	110	C																																																																																																																																																																																																																																																																																																																																																																																																															
5.0	3.06	918	734	612	459	367	306	230	184	147	122	M	WHITE	DGTJ60-11008VS (50 Mesh)	2.0	2.58	774	619	516	387	310	258	194	155	124	103	C	2.5	2.88	864	691	576	432	346	288	216	173	138	115	C	3.0	3.16	948	758	632	474	379	316	237	190	152	126	C	3.5	3.41	1023	818	682	512	409	341	256	205	164	136	C	4.0	3.65	1095	876	730	548	438	365	274	219	175	146	C	5.0	4.08	1224	979	816	612	490	408	306	245	196	163	C																																																																																																																																																																																																																																																																																																																																	
WHITE	DGTJ60-11008VS (50 Mesh)	2.0	2.58	774	619	516	387	310	258	194	155	124			103	C																																																																																																																																																																																																																																																																																																																																																																																																													
		2.5	2.88	864	691	576	432	346	288	216	173	138			115	C																																																																																																																																																																																																																																																																																																																																																																																																													
		3.0	3.16	948	758	632	474	379	316	237	190	152			126	C																																																																																																																																																																																																																																																																																																																																																																																																													
		3.5	3.41	1023	818	682	512	409	341	256	205	164			136	C																																																																																																																																																																																																																																																																																																																																																																																																													
		4.0	3.65	1095	876	730	548	438	365	274	219	175	146	C																																																																																																																																																																																																																																																																																																																																																																																																															
5.0	4.08	1224	979	816	612	490	408	306	245	196	163	C																																																																																																																																																																																																																																																																																																																																																																																																																	

TABULATION BASED ON SPRAYING WATER AT 21° C.

\*NOTE: FOR 75 cm TIP SPACING MULTIPLY CHART VALUES BY 0.67.

#### DESCRIPTION:

LITERS PER HECTARE TABULATION FOR DGTJ60-110\_\_VS DRIFT GUARD TWINJET TWIN FLAT SPRAY TIP (METRIC)



## Spraying Systems Co.®

Spray Nozzles and Accessories  
P.O. Box 7900 - Wheaton, IL 60189-7900

Rev. No. 1

Ref.

DATA SHEET

### 46190M

SHEET OF