

DG TwinJet® DRIFT GUARD TWINJET TWIN FLAT SPRAY TIP WITH VisiFlo® COLOR CODING

DROPLET SIZE CATEGORIES

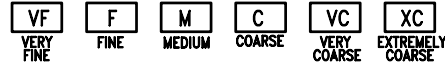

Droplet size classifications are based on BCPC specifications and in accordance with ASAE Standard S-572 at the date of printing. Classifications are subject to change.

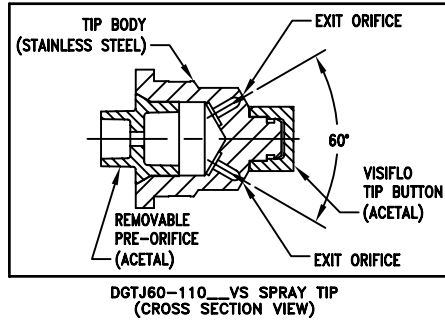

FEATURES:

- STAINLESS STEEL CONSTRUCTION WITH VISIFLO COLOR CODING FOR EXCELLENT CHEMICAL AND WEAR RESISTANCE.
- REMOVABLE PRE-ORIFICE FOR FAST AND EASY CLEANING.
- PARTICULARLY WELL SUITED FOR FUNGICIDE APPLICATION.
- TIP PRODUCES DUAL TAPERED EDGE FLAT SPRAY PATTERNS FOR UNIFORM COVERAGE IN BROADCAST SPRAYING.
- DUAL, ANGLED SPRAY PATTERNS HELP TO BETTER PENETRATE CROP CANOPY AND PROVIDE THOROUGH LEAF COVERAGE.
- OFFERS LARGER DROPLET SIZE AND IMPROVED DRIFT CONTROL AS COMPARED TO A STANDARD TWINJET SPRAY TIP OF EQUAL CAPACITY.
- AUTOMATIC ALIGNMENT WITH USE OF CP25597-*--NY (TWINJET) CAP.
- SUGGESTED SPRAY PRESSURE RANGE: 30-60 PSI.

Tip Color VisiFlo	Tip No. (Strainer Screen Size)	Liquid Pressure (psi)	Capacity 1 Nozzle (GPM)	Capacity 1 Nozzle (oz/min)	Gallons Per Acre 20 Inch Spacing*								DROP SIZE CLASSI- FICATION
					4 mph	5 mph	6 mph	8 mph	10 mph	12 mph	15 mph	20 mph	
GREEN	DGTJ60-110015VS (100 Mesh)	30	0.13	17	9.7	7.7	6.4	4.8	3.9	3.2	2.6	1.9	F
		35	0.14	18	10.4	8.3	6.9	5.2	4.2	3.5	2.8	2.1	F
		40	0.15	19	11.1	8.9	7.4	5.6	4.5	3.7	3.0	2.2	F
		50	0.17	22	12.6	10.1	8.4	6.3	5.0	4.2	3.4	2.5	F
		60	0.18	23	13.4	10.7	8.9	6.7	5.3	4.5	3.6	2.7	F
		70	0.20	26	14.9	11.9	9.9	7.4	5.9	5.0	4.0	3.0	F
YELLOW	DGTJ60-11002VS (100 Mesh)	30	0.17	22	12.6	10.1	8.4	6.3	5.0	4.2	3.4	2.5	M
		35	0.19	24	14.1	11.3	9.4	7.1	5.6	4.7	3.8	2.8	M
		40	0.20	26	14.9	11.9	9.9	7.4	5.9	5.0	4.0	3.0	M
		50	0.22	28	16.3	13.1	10.9	8.2	6.5	5.4	4.4	3.3	F
		60	0.24	31	17.8	14.3	11.9	8.9	7.1	5.9	4.8	3.6	F
		70	0.26	33	19.3	15.4	12.9	9.7	7.7	6.4	5.1	3.9	F
BLUE	DGTJ60-11003VS (100 Mesh)	30	0.26	33	19.3	15.4	12.9	9.7	7.7	6.4	5.1	3.9	C
		35	0.28	36	21	16.6	13.9	10.4	8.3	6.9	5.5	4.2	M
		40	0.30	38	22	17.8	14.9	11.1	8.9	7.4	5.9	4.5	M
		50	0.34	44	25	20	16.8	12.6	10.1	8.4	6.7	5.0	M
		60	0.37	47	27	22	18.3	13.7	11.0	9.2	7.3	5.5	M
		70	0.40	51	30	24	19.8	14.9	11.9	9.9	7.9	5.9	M
RED	DGTJ60-11004VS (50 Mesh)	30	0.35	45	26	21	17.3	13.0	10.4	8.7	6.9	5.2	C
		35	0.37	47	27	22	18.3	13.7	11.0	9.2	7.3	5.5	C
		40	0.40	51	30	24	19.8	14.9	11.9	9.9	7.9	5.9	C
		50	0.45	58	33	27	22	16.7	13.4	11.1	8.9	6.7	C
		60	0.49	63	36	29	24	18.2	14.6	12.1	9.7	7.3	M
		70	0.53	68	39	31	26	19.7	15.7	13.1	10.5	7.9	M
GRAY	DGTJ60-11006VS (50 Mesh)	30	0.52	67	39	31	26	19.3	15.4	12.9	10.3	7.7	C
		35	0.56	72	42	33	28	21	16.6	13.9	11.1	8.3	C
		40	0.60	77	45	36	30	22	17.8	14.9	11.9	8.9	C
		50	0.67	86	50	40	33	25	19.9	16.6	13.3	9.9	C
		60	0.73	93	54	43	36	27	22	18.1	14.5	10.8	C
		70	0.79	101	59	47	39	29	23	19.6	15.6	11.7	M
WHITE	DGTJ60-11008VS (50 Mesh)	30	0.69	88	51	41	34	26	20	17.1	13.7	10.2	C
		35	0.75	96	56	45	37	28	22	18.6	14.9	11.1	C
		40	0.80	102	59	48	40	30	24	19.8	15.8	11.9	C
		50	0.89	114	66	53	44	33	26	22	17.6	13.2	C
		60	0.98	125	73	58	49	36	29	24	19.4	14.6	C
		70	1.06	136	79	63	52	39	31	26	21	15.7	C
80	1.13	145	84	67	56	42	34	28	22	16.8	C		

TABULATION BASED ON SPRAYING WATER AT 70° F.

*NOTE: FOR 15 INCH TIP SPACING MULTIPLY CHART VALUES BY 1.33. FOR 30 INCH TIP SPACING MULTIPLY CHART VALUES BY 0.67.

TYPICAL APPLICATIONS:

- EXCELLENT FOR POST-EMERGE CONTACT HERBICIDE APPLICATIONS—MINIMUM SPRAY PRESSURE OF 30 PSI.
- EXCELLENT FOR FUNGICIDE APPLICATIONS —MINIMUM SPRAY PRESSURE OF 30 PSI.

SPRAY ANGLE	OPTIMUM SPRAY HEIGHT	
	20" SPACING	30" SPACING
110°	20"	30"

DESCRIPTION:

GALLONS PER ACRE TABULATION
FOR DGTJ60-110__VS
DRIFT GUARD TWINJET
TWIN FLAT SPRAY TIPS



Spraying Systems Co.®

Spray Nozzles and Accessories
P.O. Box 7900 - Wheaton, IL 60189-7900

Rev. No. 1

Ref.

DATA SHEET

46190

SHEET OF