

THE 39535-P2-1/8 AIR CHEMSAVER IS DESIGNED AS A PNEUMATIC SHUT-OFF VALVE FOR USE ON QUICK TEEJET NOZZLE ASSEMBLIES. AIR PRESSURE IS USED TO OPEN THE VALVE AND A SPRING IS USED TO CLOSE THE VALVE.

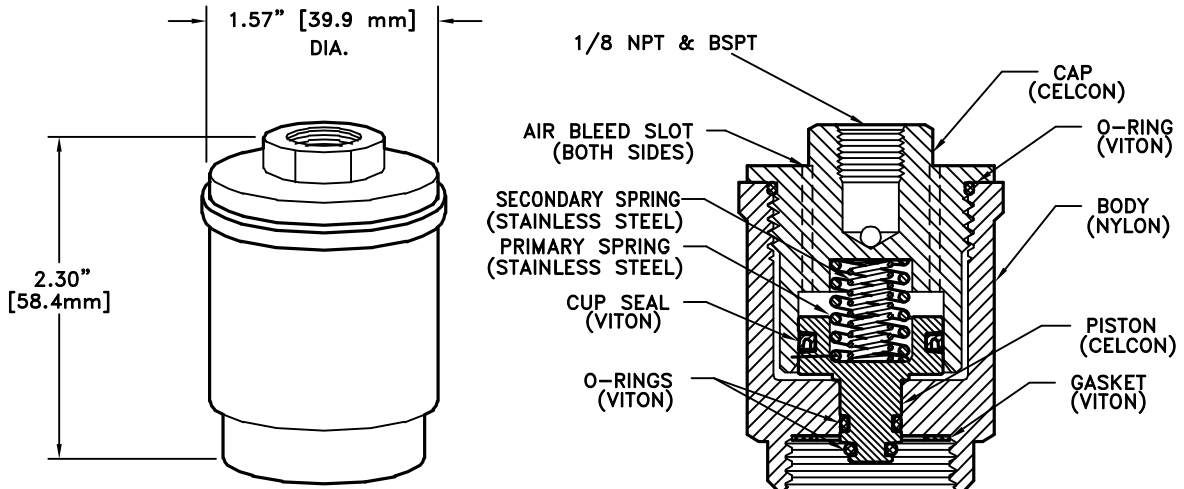

MATERIALS

- MATERIALS EXPOSED TO AIR: STAINLESS STEEL, VITON®, CELCON® AND NYLON.
- MATERIALS EXPOSED TO SYSTEM FLUID: VITON, CELCON AND NYLON.

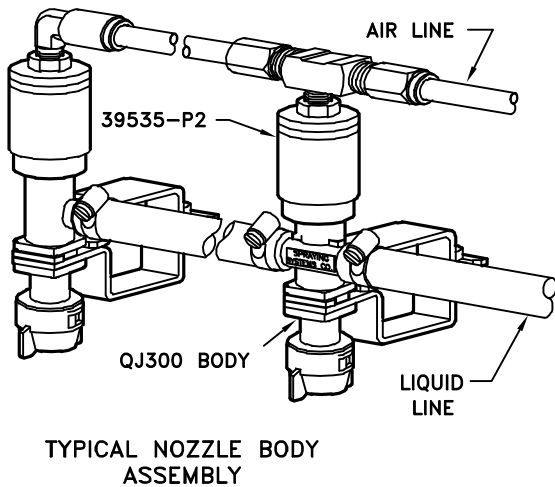

PNEUMATIC LINE

- MINIMUM 60 PSI (4.1 Bar) OPENING AIR PRESSURE.
- 2.1×10^{-4} CF/CYCLE (5.9×10^{-3} L/CYCLE) AIR CONSUMPTION PER 39535 VALVE.
- 39535-P2 REPLACES DIAPHRAGM AND CHECK VALVE END CAP ASSEMBLY.
- 39535-P2 VALVE IS NORMALLY CLOSED.

SYSTEM FLUID

- MAXIMUM 150 PSI (10 Bar) LIQUID PRESSURE.
- MUST BE COMPATIBLE WITH VITON, CELCON AND NYLON.

DESCRIPTION:

(B)39535-P2-1/8
PISTON TYPE
AIR CHEMSAVER®
SHUT-OFF VALVE
(NPT & BSPT CONNECTION)



Spraying Systems Co.®

Spray Nozzles and Accessories
P.O. Box 7900 - Wheaton, IL 60189-7900

Rev. No.

Ref.

Data Sheet No.

39535-P2

SHEET OF