

MODEL No.	INLET AND OUTLET CONN.
AA344M-2-3/4	3/4" N.P.T. (F)
AA344M-2-1	1" N.P.T. (F)
AAB344M-2-3/4	3/4" B.S.P.T. (F)
AAB344M-2-1	1" B.S.P.T. (F)

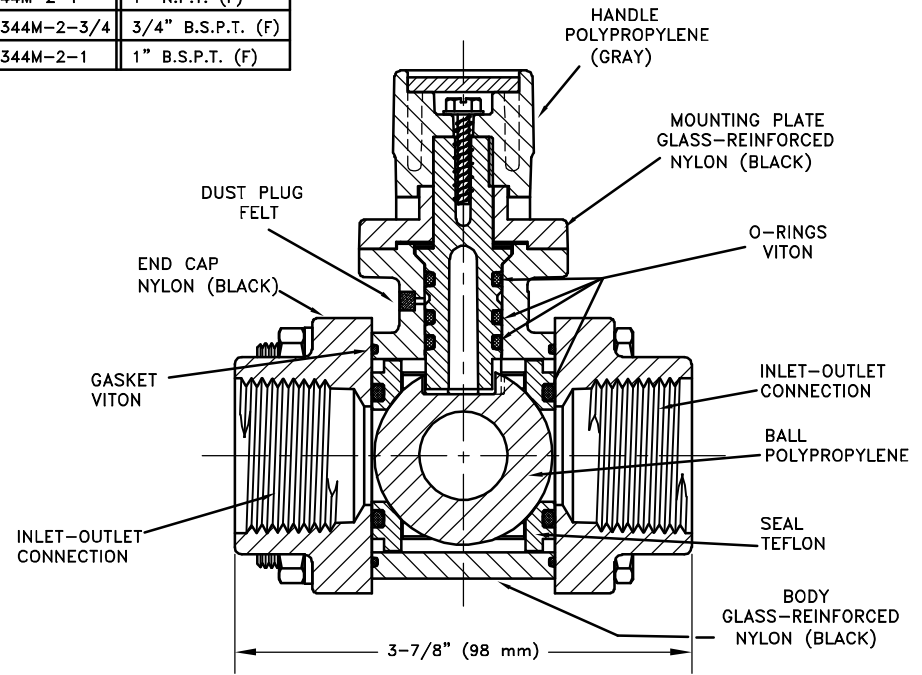

FEATURES:

- EASILY INSTALLED IN SYSTEM. (FLOWS EITHER DIRECTION).
- MAXIMUM OPERATING PRESSURE - 300 psi (20 bar).
- MATERIAL OF CONSTRUCTION OFFER EXCELLENT CORROSION RESISTANCE.
WETTED PARTS - GLASS-REINFORCED NYLON, TEFLON, POLYPROPYLENE AND VITON.
- DESIGNED FOR EASE OF ASSEMBLY AND DISASSEMBLY.
- UNRESTRICTED FLOW WHEN WIDE OPEN 5 psi (0.35 bar) PRESSURE DROP FOR 32 GPM (121 l/min) FLOW.
- QUARTER TURN OF HANDLE FROM SHUT-OFF TO FULL FLOW.

DESCRIPTION:
No. AA344M-2 MANUAL
CONTROL BALL VALVE



Spraying Systems Co.
Spray Nozzles and Accessories
P.O. Box 7900 - Wheaton, Il. 60189-7900

Rev. No. 4

Data Sheet No.

Ref.

344M-2

SHEET OF