

TO INSTALL NOZZLE  
 DRILL .280" (7 mm) DIA. HOLE  
 IN PIPE, DEBURR, THEN  
 INSERT SPLIT-EYELET INLET  
 AND CLAMP ASSEMBLY IN PLACE

MOLDED NYLON (BLACK)  
 UPPER CLAMP FITS 1/2"  
 PIPE OR 20mm TUBING

EPDM O-RING

MOLDED NYLON  
 (BLACK) MAIN BODY  
 WITH LOWER CLAMP

SELF-TAPPING STAINLESS  
 STEEL SCREW

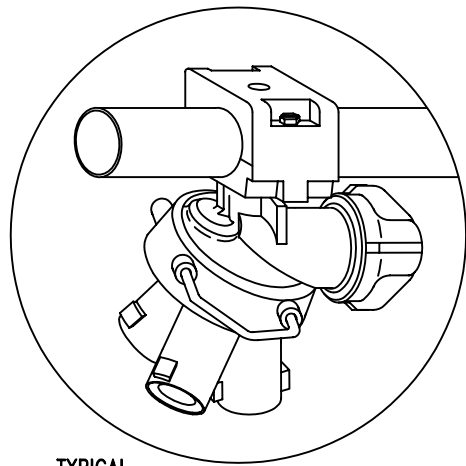
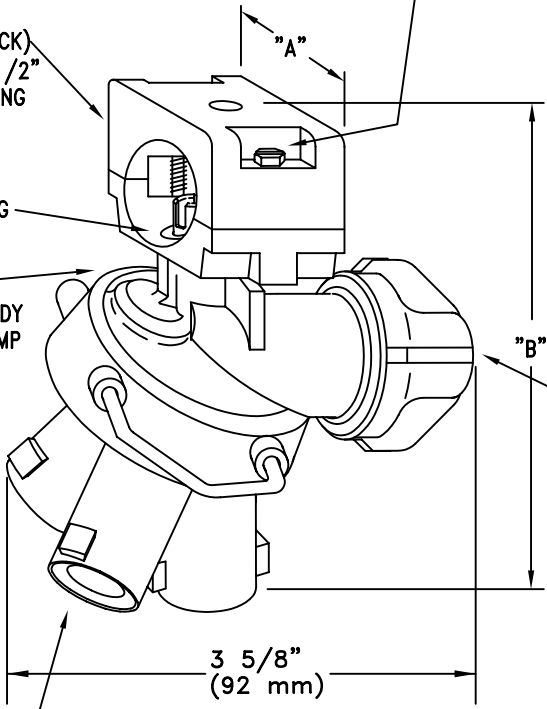

TYPICAL  
 APPLICATION

No. 21950-10-NYB  
 CHEMSAVER END CAP  
 ASB. NYLON (BLACK)

QUICK TEEJET®  
 OUTLET BODY  
 MOLDED ACETAL  
 (BLACK)  
 3 - TOTAL

PIPE SIZE	"A" (APPROX)	"B" (APPROX)
1/2", 20mm	1 11/16" (43 mm)	4 3/16" (106 mm)

U.S. PATENT Nos. 4527745,  
 D280125, OTHER U.S. AND  
 FOREIGN PATENTS GRANTED  
 OR PENDING

OTHER FEATURES:

- QUICK HAND INDEXING WITH CHOICE OF THREE DIFFERENT SPRAY TIPS FOR EASIER CHANGING OF SPRAY PATTERNS OR APPLICATION RATES.
- DRIP-FREE POSITIVE SHUT-OFF.
- SHUT-OFF POSITION PROVIDED BETWEEN ANY TWO SPRAYING POSITIONS.
- FAST AND EASY WAY TO MOUNT SPRAY NOZZLES TO A BOOM.
- MADE OF CORROSION RESISTANT MATERIALS.
- MAXIMUM OPERATING PRESSURE - 150 PSI (10 bar).

DESCRIPTION:  
**24216AX7**  
 QUICK TEEJET TRIPLE  
 OUTLET NOZZLE BODY



**Spraying Systems Co.®**  
 Spray Nozzles and Accessories  
 P.O. Box 7900 - Wheaton, Il. 60189-7900

Rev. No.  
 Ref.

DATA SHEET  
**24216AX7**  
 SHEET OF