

UPPER CLAMP MOUNTING DETAIL		
BODY SIZE	BOLT DIAMETER	HEX SIZE (FLATS)
1/2, 3/4	1/4"	7/16"
1/2M, 20mm	M8	13mm

TO INSTALL NOZZLE
 DRILL 3/8" (9.5 mm) DIA. HOLE
 IN PIPE, DEBURR, THEN
 INSERT SPLIT-EYELET INLET
 AND CLAMP ASSEMBLY IN PLACE

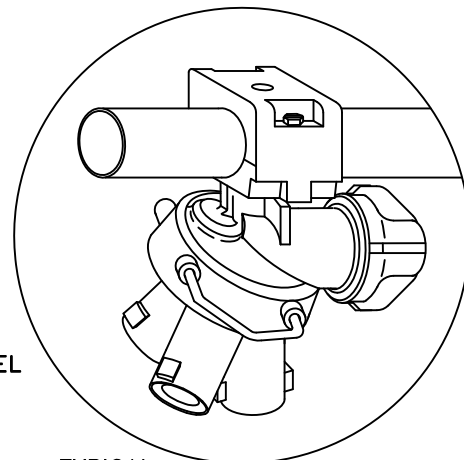

TYPICAL APPLICATION

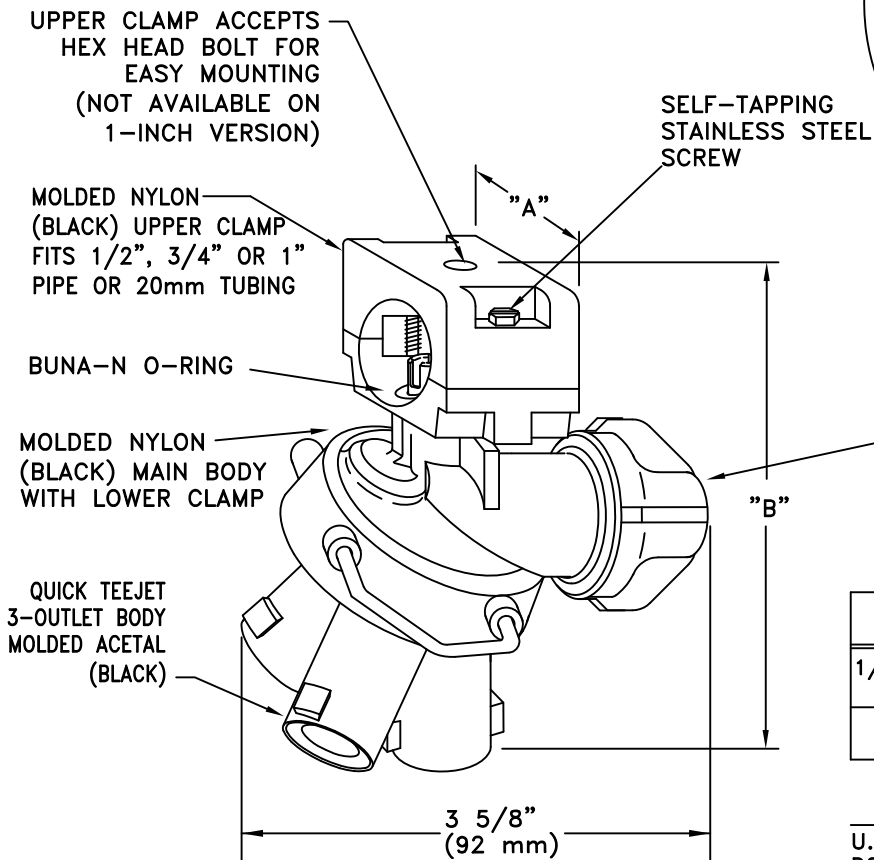

No. 21950-10-NYB
 CHEMSAVER END CAP
 ASB. NYLON (BLACK)

PIPE SIZE	"A" (APPROX)	"B" (APPROX)
1/2", 3/4" 20mm	1 11/16" (43 mm)	4 3/16" (106 mm)
1"	2 9/16" (65 mm)	4 11/32" (110 mm)

U.S. PATENT Nos. 4527745,
 D280125, OTHER U.S. AND
 FOREIGN PATENTS GRANTED
 OR PENDING

OTHER FEATURES:

- QUICK HAND INDEXING WITH CHOICE OF THREE DIFFERENT SPRAY TIPS FOR EASIER CHANGING OF SPRAY PATTERNS OR APPLICATION RATES.
- DRIP-FREE POSITIVE SHUT-OFF.
- SHUT-OFF POSITION PROVIDED BETWEEN ANY TWO SPRAYING POSITIONS.
- FAST AND EASY WAY TO MOUNT SPRAY NOZZLES TO A BOOM.
- MADE OF CORROSION RESISTANT MATERIALS.
- MAXIMUM OPERATING PRESSURE - 150 PSI (10 bar).

DESCRIPTION:

NO. 24216A-___-NYB
 QUICK TEEJET® TRIPLE
 OUTLET NOZZLE BODY



Spraying Systems Co.®

Spray Nozzles and Accessories
 P.O. Box 7900 - Wheaton, Il. 60189-7900

Rev. No. 2

Ref.

DATA SHEET

24216A

SHEET OF