

THE No. 23520-1/2-PP THROTTLING VALVE IS SPECIFICALLY DESIGNED FOR USE IN THE BYPASS (OUTLET 2) LINE OF THE 144-1-3 SOLENOID OPERATED DIRECTOVALVE (SEE D.S. 144-1-3). THIS THROTTLING VALVE, WHEN INSTALLED IN THE BYPASS-TO-TANK LINE, MAY BE ADJUSTED TO CREATE A PRESSURE DROP EQUAL TO THE LINE PRESSURE OF THAT PARTICULAR BOOM SECTION. THEN WHEN THE OPERATOR TURNS THE BOOM SECTION ON OR OFF, THE PRESSURE IN THE REMAINING BOOM SECTION WILL NOT BE AFFECTED. THE No. 23520-1/2-PP THROTTLING VALVE ALSO PROVIDES GOOD CONTROL IN ANY FLUID SYSTEM AS A LOAD VALVE.

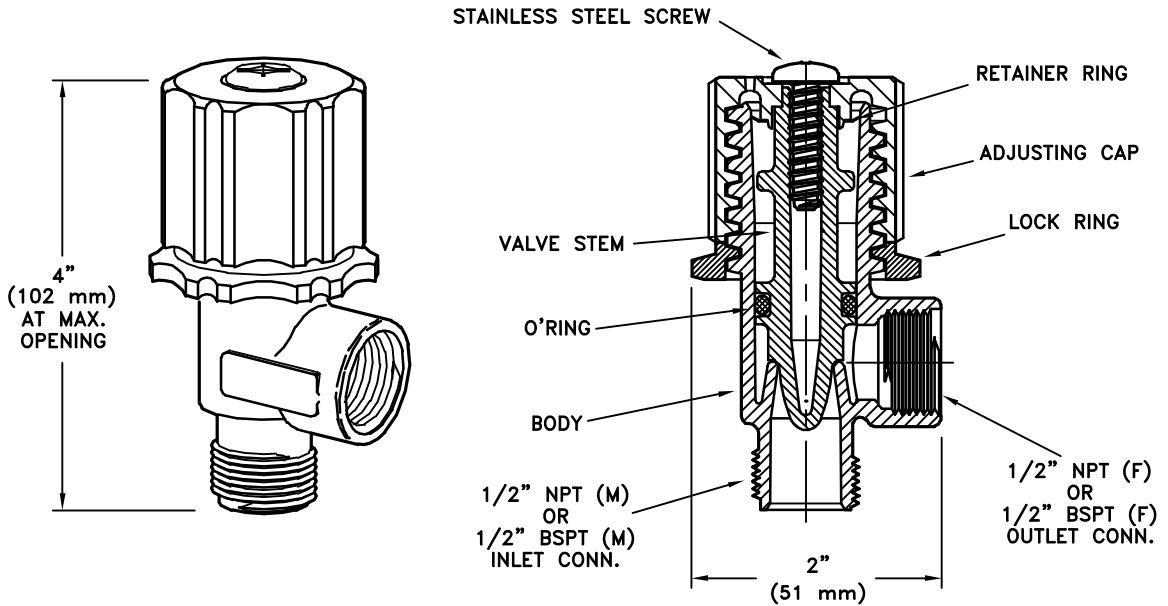

MATERIAL - POLYPROPYLENE WITH EPDM O-RING (VITON OPTIONAL), STAINLESS STEEL SCREW AND ZINC PLATED STEEL RETAINER RING.

FLOW RATES (IN FULLY OPEN POSITION)													
10 P.S.I. (0.7 bar)		20 P.S.I. (1.4 bar)		30 P.S.I. (2.1 bar)		40 P.S.I. (2.8 bar)		60 P.S.I. (4.1 bar)		80 P.S.I. (5.5 bar)		100 P.S.I. (6.9 bar)	
GPM	L/min	GPM	L/min	GPM	L/min	GPM	L/min	GPM	L/min	GPM	L/min	GPM	L/min
8	30	12	45	14	53	16	61	20	76	23	87	25	95

FEATURES:

- MAXIMUM RECOMMENDED PRESSURE - 150 P.S.I. (10.4 bar).
- COMPACT SIZE.
- ADJUSTING CAP TO VARY FLOW THROUGH VALVE WITH LOCK RING TO MAINTAIN SETTING.
- POSITIVE SHUT-OFF.
- 2 1/2 TURNS TO FULLY OPEN.
- WETTED PARTS ARE POLYPROPYLENE AND EPDM (VITON OPTIONAL).

DESCRIPTION:

**NO. 23520-1/2-PP
THROTTLING VALVE**



Spraying Systems Co.®

**Spray Nozzles and Accessories
P.O. Box 7900 - Wheaton, IL 60189-7900**

Rev. No. 3

Ref.

Data Sheet No.

23520-1/2

SHEET OF