

THE MODEL 22670 TRIGGERJET SPRAY GUN IS MADE OF MOLDED POLYPROPYLENE WITH A POLYESTER EXTENSION. IT IS LIGHTWEIGHT AND IS DESIGNED FOR COMFORT AND EASE OF OPERATION. THIS SPRAY GUN IS ALSO AVAILABLE WITHOUT EXTENSION.

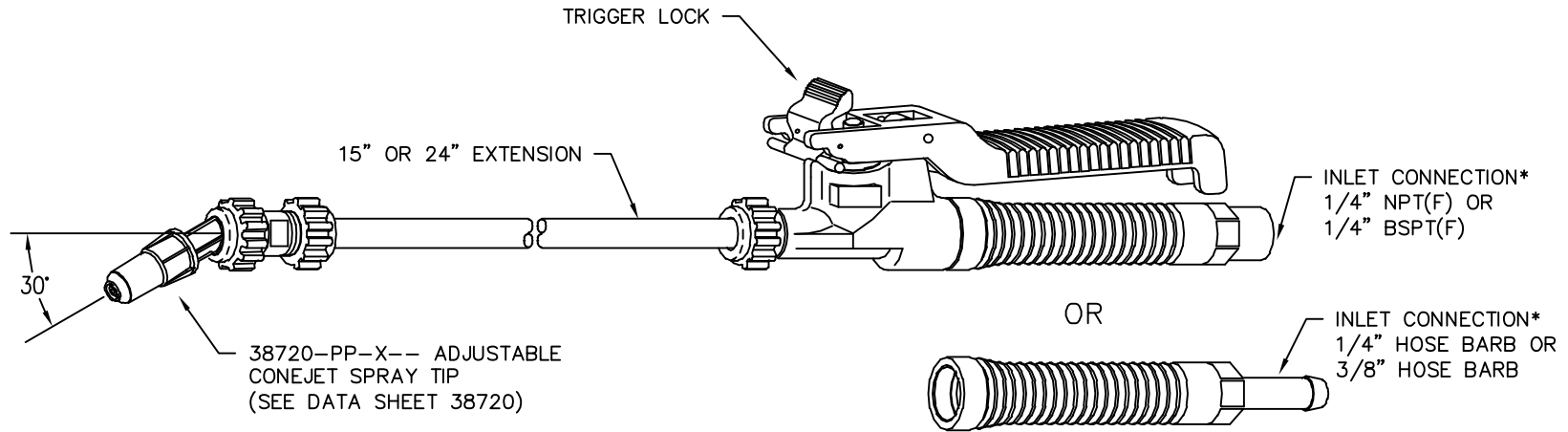

FEATURES:

- IN ADDITION TO THE 15" AND 24" EXTENSIONS THIS SPRAY GUN CAN BE ORDERED WITHOUT EXTENSION AS 22650-PP--VI.
- TRIGGER LOCK PERMITS LOCKING OF VALVE IN THE OPEN POSITION FOR CONTINUOUS FLOW.
- REPLACEABLE INTERNAL SHUT-OFF DIAPHRAGM MADE OF VITON.
- 150 PSI (10 BAR) MAXIMUM OPERATING PRESSURE.
- THE 22670 SPRAY GUN INCLUDES THE 38720-PP-X8 ADJUSTABLE CONEJET SPRAY TIP AS STANDARD. (OTHER TIP SIZES AVAILABLE)
- ACCEPTS ANY STANDARD SPRAYING SYSTEMS CO. SPRAY TIPS AND TIP STRAINERS.

DESCRIPTION:
NO. 22670-PP-TRIGGERJET® SPRAY GUN WITH EXTENSION AND SPRAY TIP



Spraying Systems Co.®

Spray Nozzles and Accessories
 P.O. Box 7900 - Wheaton, IL 60189-7900

Rev. No. 4

Ref.

Data Sheet No.

22670

SHEET OF