

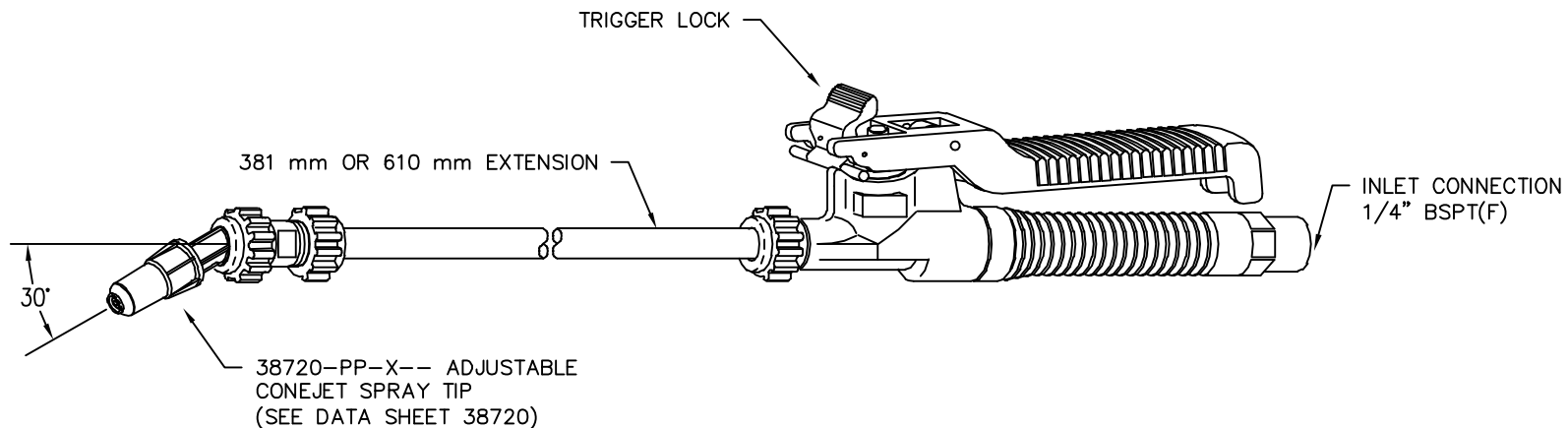

THE MODEL B22670 TRIGGERJET SPRAY GUN IS MADE OF MOLDED POLYPROPYLENE WITH A POLYESTER EXTENSION. IT IS LIGHTWEIGHT AND IS DESIGNED FOR COMFORT AND EASE OF OPERATION. THIS SPRAY GUN IS ALSO AVAILABLE WITHOUT EXTENSION.



FEATURES:

- IN ADDITION TO THE 381mm AND 610mm EXTENSIONS THIS SPRAY GUN CAN BE ORDERED WITHOUT EXTENSION AS B22650-PP--VI.
- TRIGGER LOCK PERMITS LOCKING OF VALVE IN THE OPEN POSITION FOR CONTINUOUS FLOW.
- REPLACEABLE INTERNAL SHUT-OFF DIAPHRAGM MADE OF VITON.
- 10 BAR (150 psi) MAXIMUM OPERATING PRESSURE.
- THE B22670 SPRAY GUN INCLUDES THE 38720-PP-X8 ADJUSTABLE CONEJET SPRAY TIP AS STANDARD. (OTHER TIP SIZES AVAILABLE)
- ACCEPTS ANY STANDARD SPRAYING SYSTEMS CO. SPRAY TIPS AND TIP STRAINERS.

DESCRIPTION:
NO. B22670-PP-TRIGGERJET® SPRAY GUN WITH EXTENSION AND SPRAY TIP

 Spraying Systems Co.® Spray Nozzles and Accessories P.O. Box 7900 - Wheaton, Il. 60189-7900	
Rev. No. 1	Data Sheet No.
Ref.	22670M
	SHEET OF