

TRIGGERJET NO.	TO FIT ROSE I.D.	LENGTH
22650-PP-300-VI	1/4"	7 11/16" (195 mm)
22650-PP-406-VI	3/8"	7 11/16" (195 mm)

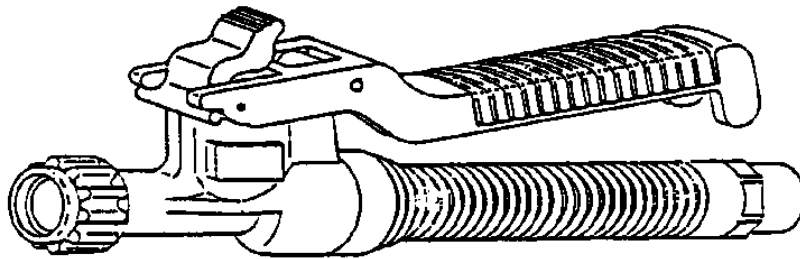

TRIGGERJET NO.	INLET CONN.	LENGTH
22650-PP-1/4-VI	1/4" NPT (F)	7 3/16" (183 mm)
B22650-PP-1/4-VI	1/4" BSPT (F)	7 3/16" (183 mm)

THE NO. 22650-PP--VI TRIGGERJET HAND OPERATED SPRAY GUN IS MADE OF MOLDED POLYPROPYLENE. IT IS LIGHT WEIGHT AND IS DESIGNED FOR COMFORT AND EASE OF OPERATION. THE TRIGGERJET IS ALSO AVAILABLE WITH EXTENSION (SEE DATA SHEET 22670).

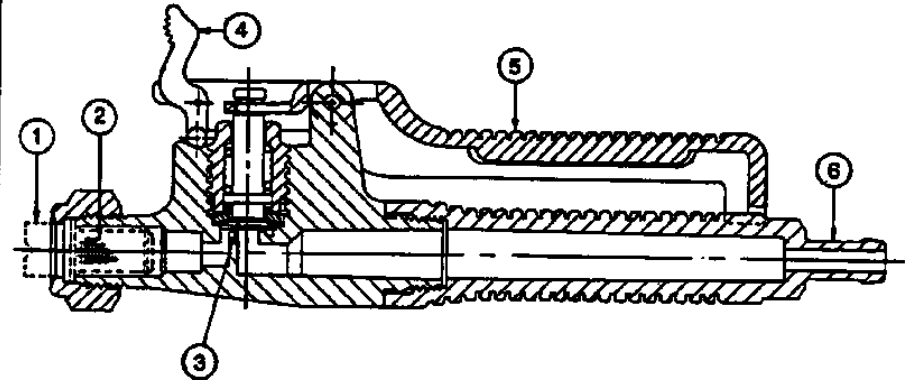

FEATURES:

- ① THE NO. 22650-PP TRIGGERJET CAN BE USED WITH ALL TEEJET SPRAY TIPS AS THE MULTEEJET TIP OR ADJUSTABLE CONEJET ASSEMBLIES.
- ② STANDARD TEEJET STRAINER ASSEMBLY PREVENTS CLOGGING OF ORIFICE.
- ③ REPLACEABLE DIAPHRAGM MADE OF EPDM RUBBER.
- ④ TRIGGER LOCK...PERMITS LOCKING VALVE IN OPEN POSITION FOR CONTINUOUS FLOW OF LIQUID.
- ⑤ TRIGGER...DESIGNED FOR EASE AND COMFORT IN OPERATION.
- ⑥ CHOICE OF INLET CONNECTIONS (SEE TABLE).
- ⑦ 150 PSI (10 bar) PRESSURE RATING.

DESCRIPTION:
NO. 22650-PP--VI
TRIGGERJET SPRAY GUN



Spraying Systems Co.
Spray Nozzles and Accessories
P.O. Box 7900 - Wheaton, IL 60189-7900

Rev. No. 3

Data Sheet No.

Ref.

22650

SHEET OF