

No. 21950-10-NYB CHEMSAVER® END CAP ASSEMBLY, NYLON (BLACK)

U.S. PATENT No.'S, 4527745, D280125, OTHER U.S. AND FOREIGN PATENTS GRANTED OR PENDING.

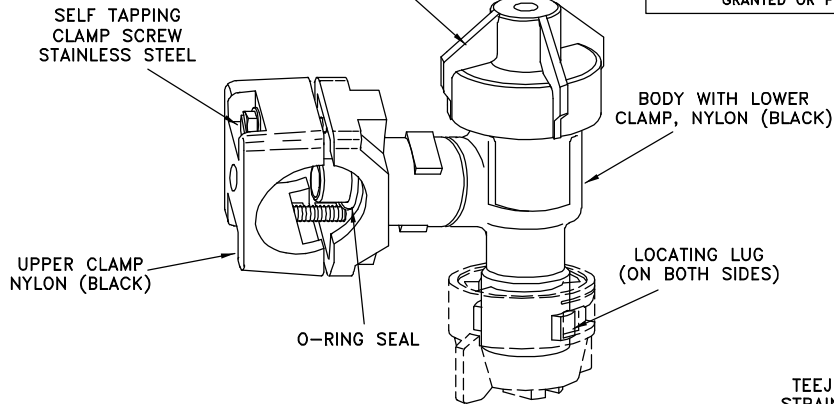

FEATURES:

- SPRAY TIP AND CHECK VALVE MOUNTED BEHIND BOOM FOR GREATER PROTECTION FROM DAMAGE.
- FAST AND EASY WAY TO MOUNT SPRAY NOZZLES TO HEADERS.
- AUTOMATIC SELF-ALIGNMENT OF FLAT SPRAY PATTERNS.
- QUICK CHANGE OF INTERCHANGEABLE SPRAY TIPS.
- DRIP FREE POSITIVE SHUT-OFF.
- MADE OF CORROSION RESISTANT MATERIALS.
- STANDARD O-RING MADE OF BUNA-N, VITON (OPTIONAL).
- STANDARD DIAPHRAGM IS EPDM, VITON® AND TEFLON® DIAPHRAGM (OPTIONAL).
- OPENING PRESSURE - 10 PSI (0.7 bar).
- MAXIMUM OPERATING PRESSURE - 300 PSI (20 bar).
- QUICK TEEJET CAPS, GASKETS, TIPS AND STRAINERS NOT INCLUDED WITH BODY ASSEMBLY.

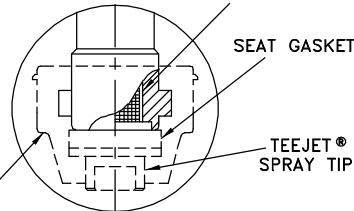
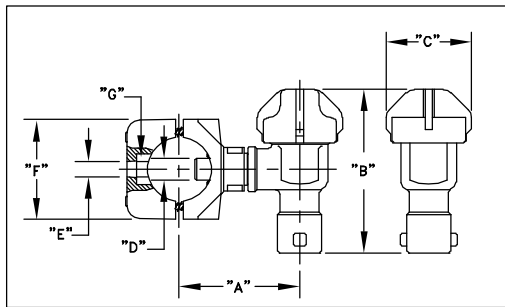

QUICK TEEJET CAP WITH GROOVES THAT FIT LOCATING LUGS OF BODY, CELCON.

HOW TO ORDER:

FOR DIAPHRAGM QUICK TEEJET BODY ASSEMBLY SPECIFY PART NUMBER:
 EXAMPLE: QJ22187-1/2-NYB QUICK TEEJET NOZZLE BODY ASSEMBLY.

TO INSTALL ASSEMBLY DRILL 3/8" (9.5 mm) HOLE IN PIPE, DEBURR THEN INSERT SPLIT-EYELET INLET AND CLAMP ASSEMBLY IN PLACE.

BODY ASSEMBLY No.	TO CLAMP ON	"A"	"B"	"C"	"D"	"E"	"F"	"G"
QJ22187-1/2-NYB	1/2" PIPE, 13/16" & 7/8" O.D. TUBINGS	2" (51 mm)	3 1/4" (83 mm)	1 7/16" (37 mm)	.370" DIA. (9.4 mm)	17/64" DIA. (6.7 mm)	1 43/64" (42 mm)	29/64" HEX. (11.5 mm)
QJ22187-3/4-NYB	3/4" PIPE 1" & 1 1/16" O.D. TUBINGS							
QJ22187-1-NYB	1" PIPE 1" & 1 1/16" O.D. TUBINGS	2 1/8" (54 mm)				N/A	2 35/64" (65 mm)	N/A

DESCRIPTION:
 NO. QJ22187--NYB
 SPLIT-EYELET QUICK TEEJET
 DIAPHRAGM CHECK VALVE
 NOZZLE BODY ASSEMBLIES



Spraying Systems Co.®
 Spray Nozzles and Accessories
 P.O. Box 7900 - Wheaton, Il. 60189-7900

Rev. No. 1

Data Sheet No.

Ref.

22187

SHEET OF