

MATERIAL:
BRASS CONSTRUCTION
WITH STAINLESS
STEEL SPRING.

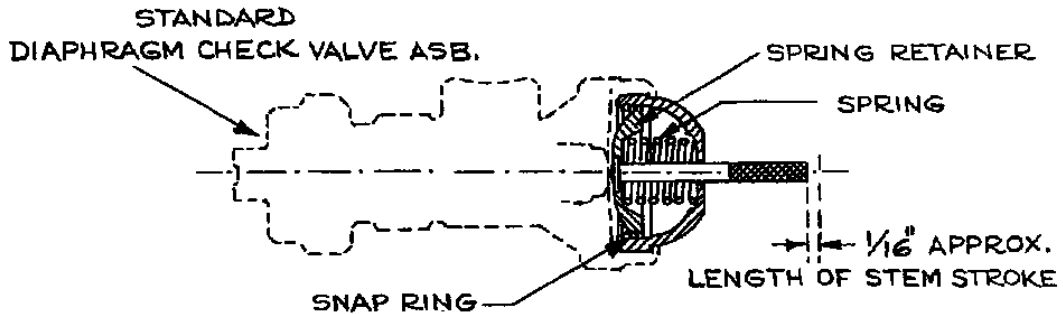
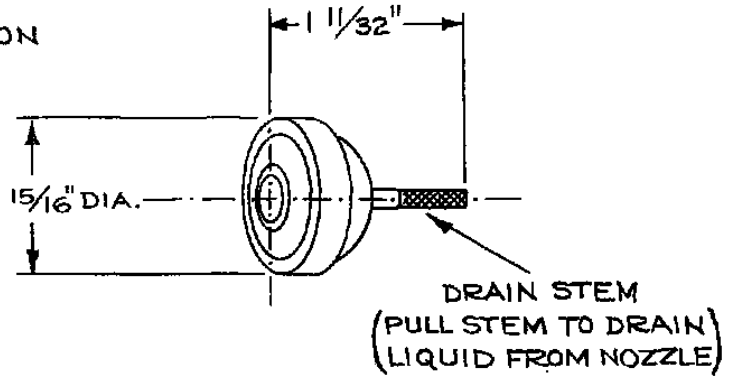

NO. 19557 END CAP SUB-ASSEMBLY REPLACES NO. 9758 END CAP SUB-ASSEMBLY. WHEN USED WITH ANY STANDARD DIAPHRAGM CHECK VALVE (4664A, 4666A, 6140, 10742, 6135). IT PROVIDES A QUICK AND SIMPLE MEANS FOR DRAINING LIQUID FROM THE NOZZLE AFTER THE PRESSURE IS SHUT OFF. (THE DRAIN STEM CAN ALSO BE ACTUATED TO DISLodge ANY PARTICLES WHICH MAY BE PREVENTING PROPER VALVE SHUT-OFF.)

DESCRIPTION:

NO. 19557 END CAP
SUB-ASSEMBLY
WITH DRAIN STEM FOR
DIAPHRAGM CHECK VALVE
TEEJET NOZZLE



Spraying Systems Co.[®]

Spray Nozzles and Accessories
P.O. Box 7900 - Wheaton, Il. 60189-7900

Rev. No. 1

Ref.

Data Sheet No.

19553

SHEET OF