

24 NOZZLES				LIQUID PRESSURE IN kPa	24 NOZZLE TOTAL CAPACITY IN Lit/min	LITERS PER HECTARE											
DIAPHRAGM TEEJET NOZZLE WITH ORIFICE AND CORE COMBINATION NO.	ORIFICE NO.	CORE NO.	ORIFICE DIA.			12m SWATH			15m SWATH			18m SWATH					
						100 km/h	130 km/h	160 km/h	100 km/h	130 km/h	160 km/h	100 km/h	130 km/h	160 km/h			
D14 - 25	D14	25	5.6 mm	150	68.1	34	26	21	27	21	17.0	23	17.5	14.2			
				200	79.0	40	30	25	32	24	19.8	26	20	16.5			
				250	86.1	44	34	28	35	27	22	29	23	18.4			
				300	97.2	49	37	30	39	30	24	32	25	20			
				350	104	52	40	33	42	32	26	35	27	22			
400	112	56	43	35	45	34	28	37	29	23							
D6 - 46	D6	46	2.4 mm	150	74.5	37	29	23	30	23	18.6	26	19.1	15.5			
				200	85.4	43	33	27	34	26	21	28	22	17.8			
				250	95.4	48	37	30	38	29	24	32	24	19.9			
				300	104	52	40	33	42	32	26	35	27	22			
				350	114	57	44	35	45	35	28	38	29	24			
400	121	60	46	38	48	37	30	40	31	25							
D12 - 45	D12	45	4.8 mm	150	90.8	45	35	28	36	28	23	30	28	18.9			
				200	104	52	40	33	42	32	26	35	27	22			
				250	116	58	45	36	47	36	28	38	30	24			
				300	128	64	49	40	51	39	32	43	33	27			
				350	138	69	53	43	55	42	35	46	35	29			
400	149	74	57	47	60	46	37	50	38	31							
D14 - 45	D14	45	5.6 mm	150	102	51	39	32	41	31	25	34	26	21			
				200	117	59	45	37	47	36	29	39	30	24			
				250	132	66	51	41	53	41	33	44	34	27			
				300	144	72	56	45	58	44	36	48	37	30			
				350	156	78	60	49	63	48	39	52	40	33			
400	168	84	65	53	67	52	42	56	43	35							
D16 - 45	D16	45	6.4 mm	150	118	59	45	37	47	36	30	39	30	25			
				200	136	68	52	43	55	42	34	45	35	28			
				250	154	77	59	48	62	48	39	51	40	32			
				300	170	85	65	53	68	52	42	57	44	35			
				350	184	92	71	58	74	57	46	61	47	38			
400	197	98	76	62	79	61	49	66	51	41							
D8 - 56	D8	56	3.2 mm	150	129	63	50	40	52	40	32	43	33	27			
				200	149	75	57	47	60	46	37	50	38	31			
				250	167	83	64	52	67	51	42	56	43	35			
				300	183	91	70	57	75	56	46	61	47	38			
				350	197	99	76	62	79	61	49	66	51	41			
400	211	105	81	66	84	65	53	70	54	44							
D10 - 56	D10	56	4.0 mm	150	182	91	70	57	73	56	45	61	47	38			
				200	207	104	80	65	83	64	52	69	53	43			
				250	232	116	89	72	93	71	58	77	59	48			
				300	254	127	98	79	102	78	64	85	65	53			
				350	274	137	106	86	110	84	69	91	70	57			
400	293	147	113	92	117	90	73	98	75	61							
D12 - 56	D12	56	4.8 mm	150	213	107	82	67	85	66	53	71	55	44			
				200	243	121	93	76	97	75	61	81	62	51			
				250	268	134	103	84	107	82	67	89	69	56			
				300	295	148	114	92	118	91	74	98	76	62			
				350	318	159	122	99	127	98	79	106	82	66			
400	336	168	129	105	134	103	84	112	86	70							

TABULATION IS BASED ON WATER AT TEMPERATURE OF 21°C.

kPa = PRESSURE IN KILOPASCAL.
 Lit/min = CAPACITY IN LITERS PER MINUTE.
 km/h = GROUND SPEED OF PLANE IN KILOMETERS PER HOUR.

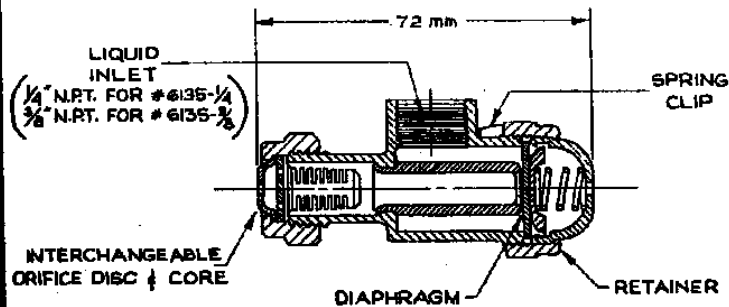

THE # 6135--DIAPHRAGM TEEJET NOZZLE CAN BE TAKEN APART BY HAND... SPRING CLIP LOCKS RETAINER IN PLACE... DIAPHRAGM IS MADE OF SPECIAL RESISTANT SYNTHETIC RUBBER WHICH IS NOT AFFECTED BY MOST LIQUIDS... EASILY REPLACED. SEE BULLETIN NO.133 FOR MORE DETAILS ON #6135--DIAPHRAGM TEEJET.

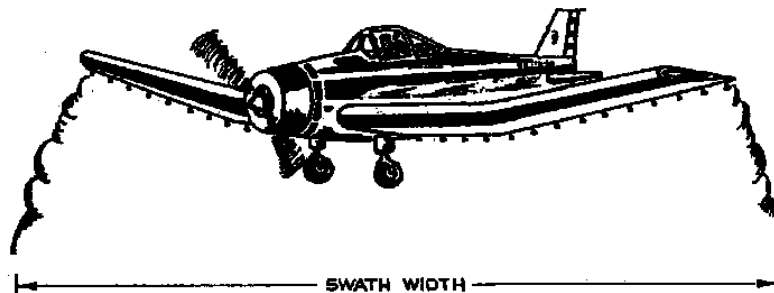

TABULATION SHOWS COVERAGES IN LITERS PER HECTARE AT VARIOUS LIQUID PRESSURES, SPEEDS AND SWATH WIDTH.

CAPACITIES ARE BASED ON 24 NOZZLES ALONG THE BOOM AND SPRAYING SIMULTANEOUSLY. FOR OTHER QUANTITIES OF NOZZLES (SAME OPERATING CONDITIONS) THE CAPACITIES ARE PROPORTIONAL... 48 NOZZLES WILL GIVE TWICE THE CAPACITIES SHOWN; 18 NOZZLES WILL GIVE 75%... ETC..

THE USUAL SPRAYING HEIGHT VARIES FROM 4m TO 5m HOWEVER. THE SPRAYING HEIGHT AND OTHER VARIABLES AS WIND VELOCITY AND DRIFTAGE HAVE NOT BEEN TAKEN INTO CONSIDERATION IN COMPUTING THE CAPACITY TABULATION.

DESCRIPTION:
 LITERS PER HECTARE
 TABULATION FOR AIRPLANE
 SPRAYING USING NO. 6135--
 DIAPHRAGM TEEJET NOZZLES
 WITH ORIFICE & CORE
 COMBINATION



Spraying Systems Co.

Spray Nozzles and Accessories
 P.O. Box 7900 - Wheaton, IL 60189-7900

Rev. No.

Data Sheet No.

17948

Ref.

SHEET OF