

MAXIMUM RECOMMENDED LIQUID PRESSURE - 800 P.S.I.

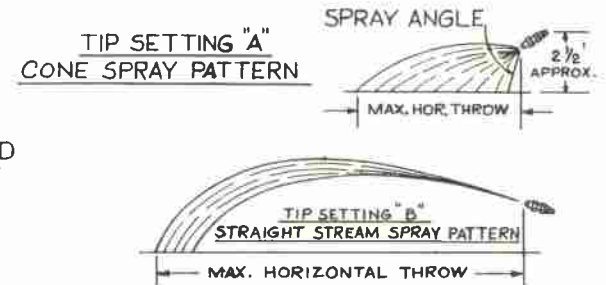
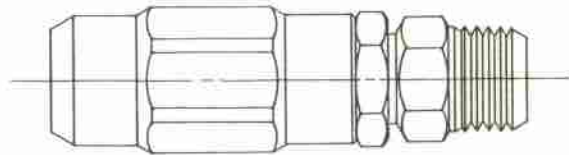

TABULATION BELOW IS BASED ON A NON-RESTRICTED FLOW TO THE #12430--AY-TC--ADJUSTABLE CONEJET.

NOZZLE NO.	MATERIAL	
	ORIFICE INSERT	CORE INSERT
12430-AY-TCHSS*	TUNGSTEN CARBIDE	HARDENED STAINLESS STEEL
12430-AY-TC*	TUNGSTEN CARBIDE	TUNGSTEN CARBIDE

* SPECIFY ORIFICE NO.

ORIFICE SUB-ASB. #16946-AYTCHSS-	PERFORMANCE	LIQUID PRESSURE IN P.S.I. (LBS. PER SQUARE INCH)											
		20		40		100		200		400		800	
		SETTING "A"	SETTING "B"	SETTING "A"	SETTING "B"	SETTING "A"	SETTING "B"	SETTING "A"	SETTING "B"	SETTING "A"	SETTING "B"	SETTING "A"	SETTING "B"
20	CAPACITY-G.P.M. SPRAY ANGLE MAX. HOR. THROW MAX. VER. THROW	.24 51° 3' -	.40 - 33' 21'	.33 56° 4' 24'	.57 - 34' -	.53 65° 5' -	.90 - 36' 26'	.75 56° 6' -	1.27 - 37' 27'	1.06 42° 6' -	1.8 - 38' 28'	1.5 31° 7' -	2.54 - 39' 29'
30	CAPACITY-G.P.M. SPRAY ANGLE MAX. HOR. THROW MAX. VER. THROW	.35 52° 4' -	.63 - 35' 22'	.50 57° 5' 25'	.90 - 36' -	.79 65° 6' -	1.4 - 38' 27'	1.12 57° 7' -	2.0 - 39' 28'	1.58 43° 7' -	2.8 - 40' 30'	2.23 32° 8' -	4.0 - 41' 31'
45	CAPACITY-G.P.M. SPRAY ANGLE MAX. HOR. THROW MAX. VER. THROW	.53 53° 4' -	1.0 - 36' 23'	.75 58° 6' 26'	1.5 - 38' -	1.2 65° 7' -	2.3 - 40' 28'	1.68 58° 8' -	3.29 - 41' 30'	2.37 44° 8' -	4.65 - 42' 32'	3.36 33° 9' -	6.57 - 43' 33'
60	CAPACITY-G.P.M. SPRAY ANGLE MAX. HOR. THROW MAX. VER. THROW	.71 54° 5' -	1.6 - 37' 24'	1.0 59° 7' -	2.3 - 39' 27'	1.6 65° 8' -	3.6 - 41' 30'	2.24 59° 9' -	5.09 - 42' 33'	3.17 45° 9' -	7.2 - 43' 34'	4.49 34° 10' -	10.2 - 44' 35'

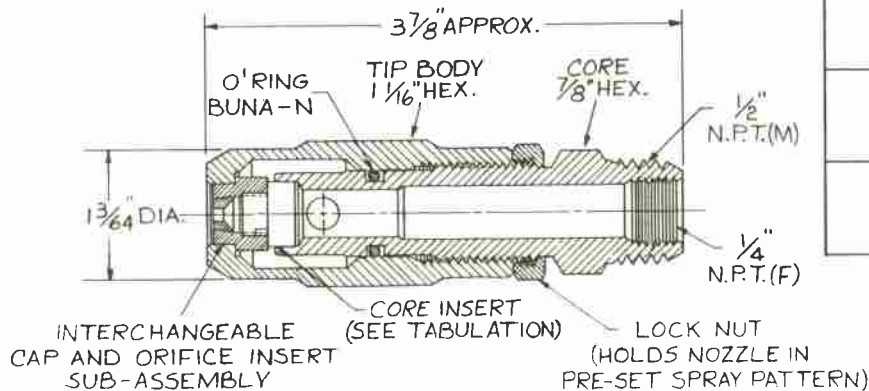

- COMPLETE RANGE OF SPRAY PATTERNS FROM HOLLOW CONE TO STRAIGHT STREAM IS OBTAINED BY: -
- (1) LOOSENING LOCKNUT SLIGHTLY AND
 - (2) UNSCREWING THE TIP BODY TWO OR THREE (MAX.) TURNS FROM ITS COMPLETELY "SCREWED-BACK" POSITION.
 - (3) TIGHTEN LOCKNUT SECURELY BEFORE RESUMING SPRAYING.

NOTE: DO NOT UNSCREW TIP BODY MORE THAN A TOTAL OF THREE TURNS FROM ITS COMPLETELY "SCREWED-BACK" SETTING.

DESCRIPTION
#12430-AY-TC --
ADJUSTABLE CONEJET
WITH TUNGSTEN
CARBIDE ORIFICE
Ref:
Revision No.

SPRAYING SYSTEMS CO.
 Spray Nozzles and Accessories
 North Avenue and Schmale Road
 Wheaton, Illinois 60187

Data Sheet No.
12429-1