

NOTE: MOTOR IS ROTATED 180° FROM NORMAL ORIENTATION TO BETTER ILLUSTRATE MOTOR DETAIL.

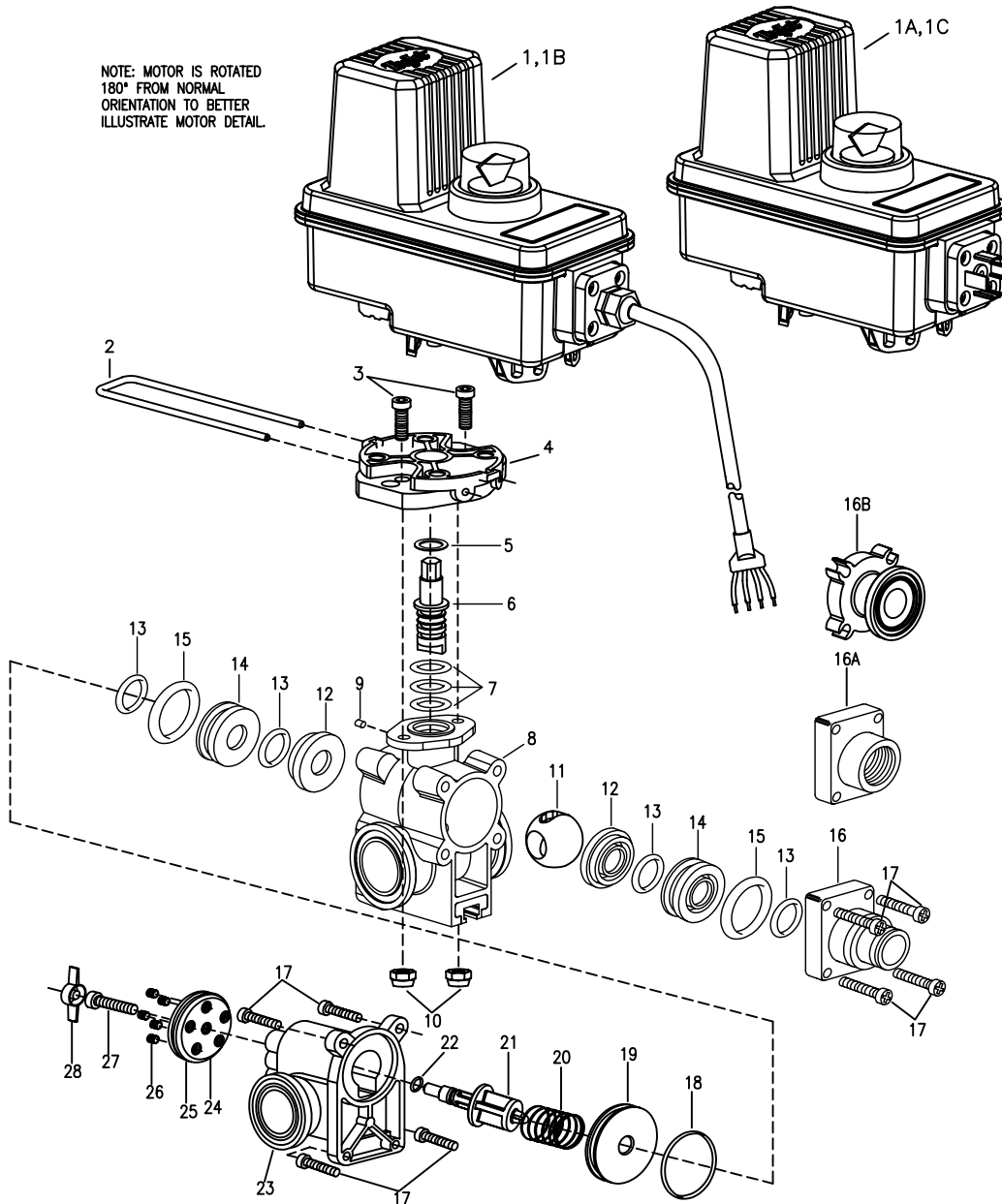

ITEM	SALES PART NO.	DESCRIPTION
1	50515-25CP03	BEC MOTOR, 25-RPM (0.6-SEC), 0.3-METER CABLE, POSITIVELY SWITCHED
	50515-25CP05	BEC MOTOR, 25-RPM (0.6-SEC), 0.5-METER CABLE, POSITIVELY SWITCHED
	50515-25CP15	BEC MOTOR, 25-RPM (0.6-SEC), 1.5-METER CABLE, POSITIVELY SWITCHED
	50515-25CP60	BEC MOTOR, 25-RPM (0.6-SEC), 6.0-METER CABLE, POSITIVELY SWITCHED
1A	50515-25DP	BEC MOTOR, 25-RPM (0.6-SEC), DIN CONNECTION, POSITIVELY SWITCHED
1B	50533-25C03	BE MOTOR, 25-RPM (0.6-SEC), 0.3-METER CABLE
	50533-25C05	BE MOTOR, 25-RPM (0.6-SEC), 0.5-METER CABLE
	50533-25C15	BE MOTOR, 25-RPM (0.6-SEC), 1.5-METER CABLE
	50533-25C60	BE MOTOR, 25-RPM (0.6-SEC), 6.0-METER CABLE
1C	50533-25D	BE MOTOR, 25-RPM (0.6-SEC), DIN CONNECTION
2	CP50517-SSPV	RETAINING CLIP, 304 STAINLESS STEEL
3	CP26197-7/8-SS	SOCKET HEAD CAP SCREW, STAINLESS STEEL (2 REQ'D)
4	CP50514-PP	MOTOR ADAPTER, POLYPROPYLENE (BLACK)
5	CP20125-TEF	THRUST WASHER, TEFLON
6	CP56614-SS	STEM, 303 STAINLESS STEEL
7	CP7717-M12X2.5-VI	O-RING, VITON (3 REQ'D)
8	CP45503-NYB	BODY, NYLON (INCLUDES MOUNTING RAIL)
9	CP20126-FELT	DUST PLUG, FELT
10	CP38435-1/4-SSNY	ELASTIC LOCKNUT, STAINLESS STEEL (2 REQ'D)
11	CP45510-1-SS	BALL, 303 STAINLESS STEEL
12	CP20103-TEF	SEAL, TEFLON (2 REQ'D)
13	CP7717-2-213-VI	O-RING, VITON (4 REQ'D)
14	CP45502-NYB	BALL SEAL SPACER, NYLON (BLACK) (2 REQ'D)
15	CP7717-2-322-VI	O-RING, VITON (2 REQ'D)
16A	CP45514-NYB	ENDCAP, NYLON (BLACK) (QUICK CONNECT)
	CP20104-3/4-NYB	ENDCAP, NYLON (BLACK) (3/4" NPT THREAD)
	CPB20104-3/4-NYB	ENDCAP, NYLON (BLACK) (3/4" BSPT THREAD)
	CP20104-1-NYB	ENDCAP, NYLON (BLACK) (1" NPT THREAD)
16B	CPB20104-1-NYB	ENDCAP, NYLON (BLACK) (1" BSPT THREAD)
	CP45253-NYB	ENDCAP, NYLON (BLACK) (50-SERIES FLANGED)
17	CP45517-1-1/8-SS	PAN HEAD SCREW, STAINLESS STEEL (8 REQ'D)
18	CP7717-2-129-VI	O-RING, VITON
19	CP45535-1-NYB	ORIFICE DISK, NYLON (BLACK)
20	CP45536-302SS	SPRING, 302 STAINLESS STEEL
21	CP46026-NYB	PLUNGER, NYLON (BLACK)
22	CP7717-5-VI	O-RING, VITON
23	CP45541-NYB	3-WAY HOUSING, NYLON (BLACK)
24	CP45534-NYB	ADJUSTMENT DISK, NYLON (BLACK)
25	CP45544-VL	STICKER, VINYL
26	CP45537-SS	SET SCREW, STAINLESS STEEL
27	CP45542-35-SS	SOCKET HEAD CAP SCREW, STAINLESS STEEL
28	CP45538-PL	THUMB SCREW KNOB, PLASTIC (BLACK)

AB460B-KIT, SPARE PARTS KIT (INCLUDES ALL ITEMS MARKED WITH *)

NOTE: (B) IN PART NUMBER INDICATES B.S.P.T INLET AND OUTLET CONNECTIONS
 * NOTE: FOR NEGATIVELY SWITCHED MOTORS SPECIFY "N" RATHER THAN "P" IN MOTOR PART NUMBER. EXAMPLE: 50515-25CN05

DESCRIPTION:
 460BEC-3C 3-WAY DIRECT VALVE
 ELECTRIC SHUT-OFF BALL VALVE MANIFOLD WITH MULTIPLE PRESET ADJUSTABLE BYPASS



Spraying Systems Co.

Spray Nozzles and Accessories
 P.O. Box 7900 - Wheaton, IL 60189-7900

Rev. No. 1

Ref.

PARTS LIST
PL460BEC-3C
 SHEET OF