

# MT600 INJECTION PUMP INSTALLATION MANUAL



**TeeJet**<sup>®</sup>  
TECHNOLOGIES

A Subsidiary of  Spraying Systems Co.<sup>®</sup>

# MT600 Injection Pump

---

## Table of Contents

Mounting .....	1
Plumbing .....	1
Cabling .....	2
Pump Power Cable .....	2
Proper Pump Tube Selection .....	2
Pump Tube Installation.....	3
Calibration.....	4
Maintenance.....	4
Flushing and Cleaning .....	4
Weekly and Seasonal Pump Maintenance .....	4
Plumbing points of attention .....	5
Electrical points of attention.....	5
Piston Pump General Specifications.....	8
Calibration Numbers .....	9
Product Warranty.....	9
Warranty Limitations and Exclusions .....	9
Disclaimer of Unstated Warranty .....	9

### Copyrights

© 2022 TeeJet Technologies. All rights reserved. No part of this document or the computer programs described in it may be reproduced, copied, photocopied, translated, or reduced in any form or by any means, electronic or machine readable, recording or otherwise, without prior written consent from TeeJet Technologies.

### Trademarks

Unless otherwise noted, all other brand or product names are trademarks or registered trademarks of their respective companies or organizations.

### Limitation of Liability

TEEJET TECHNOLOGIES PROVIDES THIS MATERIAL “AS IS” WITHOUT WARRANTY OF ANY KIND, EITHER EXPRESSED OR IMPLIED. NO COPYRIGHT LIABILITY OR PATENT IS ASSUMED. IN NO EVENT SHALL TEEJET TECHNOLOGIES BE LIABLE FOR ANY LOSS OF BUSINESS, LOSS OF PROFIT, LOSS OF USE OR DATA, INTERRUPTION OF BUSINESS, OR FOR INDIRECT, SPECIAL, INCIDENTAL, OR CONSEQUENTIAL DAMAGES OF ANY KIND, EVEN IF TEEJET TECHNOLOGIES HAS BEEN ADVISED OF SUCH DAMAGES ARISING FROM TEEJET TECHNOLOGIES SOFTWARE.

## Mounting

The MT600 injection pump is recommended to be located as close as possible to the point where chemicals are injected into the main boom supply line (as close to the delivery point as possible is the preferred injection point). A consideration should be made to use check valves between the injection pump and injection point as well as ahead of the injection point in the main flow line (refer to the plumbing diagrams on Pages 6 and 7). The location of the chemical container and the MT600 must also be considered and hose lengths kept to a minimum.

Once the location for the injection pump is selected, orient the assembly so that the pump cover is easily opened to allow access for service. All sides of the pump may need to be accessible for service purposes. The pump must be mounted in an upright position.

Five (5) US fluid ounces (150 ml) of SAE 10w30 oil must be added to each pump head via the red cap port prior to operation. The top of the oil level should always be visible somewhere in the viewing window. Avoid overfilling.

Figures 1 and 2 provide measurements and mounting holes for the pumps.

Figure 1: Bottom View

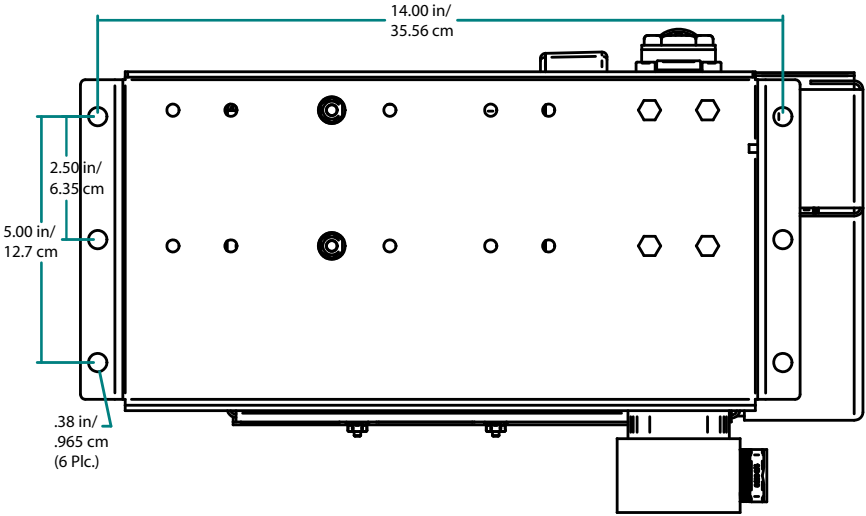
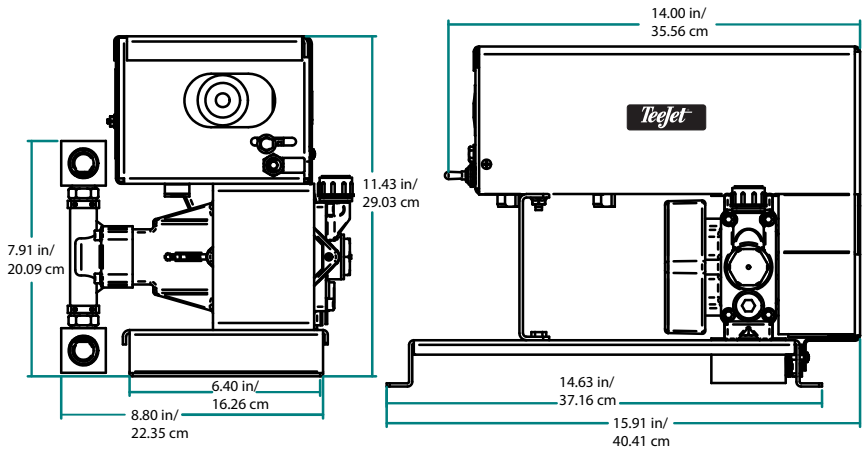

Figure 2: Side View



**NOTE:** Secure each pump firmly to eliminate vibration and possible damage to the connecting hoses and cables.

## Plumbing

Refer to the sample plumbing diagrams on Pages 6 and 7 for suggestions on how to connect the system.

# MT600 Injection Pump

## Cabling

Each MT600 injection pump is equipped with two cables:

- a pump control cable
- a pump power cable.

Refer to the sample system diagrams on Pages 6 and 7 for suggestions on how to connect the system.

**Route all cables carefully. Avoid moving parts, excessive heat, and exposure to tree limbs, stubble, and other debris. Allow enough slack at all pivot points to prevent pinching or stretching the cables.**

Secure the cables with cable fasteners and/or cable clamps.

## Pump Power Cable

Route each power cable to the vehicle battery (12 VDC only). Attach the red lead (fused) to the positive post and the black lead to the negative post of the battery.

## Proper Pump Size Selection

Use the following formula to determine the flow capacity requirements of the pump. Check the Pump Tube Selection Chart (Figure 3) to verify the proper pump tube size.

US Measurements:

$$\begin{aligned} \text{Pump Capacity} &= \text{Max. Boom Width} \times \text{Max. Speed} \times \text{Chemical Rate} \times (.00202) \\ (\text{oz/Min}) &= (\text{feet}) \times (\text{mph}) \times (\text{oz/acre}) \times (.00202) \end{aligned}$$

Metric Measurements:

$$\begin{aligned} \text{Pump Capacity} &= \text{Max. Boom Width} \times \text{Max. Speed} \times \text{Chemical Rate} \times (.00167) \\ (\text{l/Min}) &= (\text{meters}) \times (\text{kph}) \times (\text{l/ha}) \times (.00167) \end{aligned}$$

US example: A sprayer with 35 feet booms traveling at a speed of 7 mph and applying 32 oz of chemicals per acre requires a maximum pump capacity of 15.8 oz/min. (35 feet x 7 mph x 32 oz/ac x .00202 = 15.8 oz/min.) Referring to the Pump Tube Selection Chart, a 3/16 inch pump is sufficient for this rate. If 100 oz/acre of chemical is required for application, a 1/4 inch pump tube is required (35 feet x 7 mph x 100 oz/acre x .00202 = 49.49 oz/min) which exceeds the recommended range of the smaller 3/16 inch tube. (Chart is in oz/min or l/min)

Figure 3: US Pump Tube Selection Chart

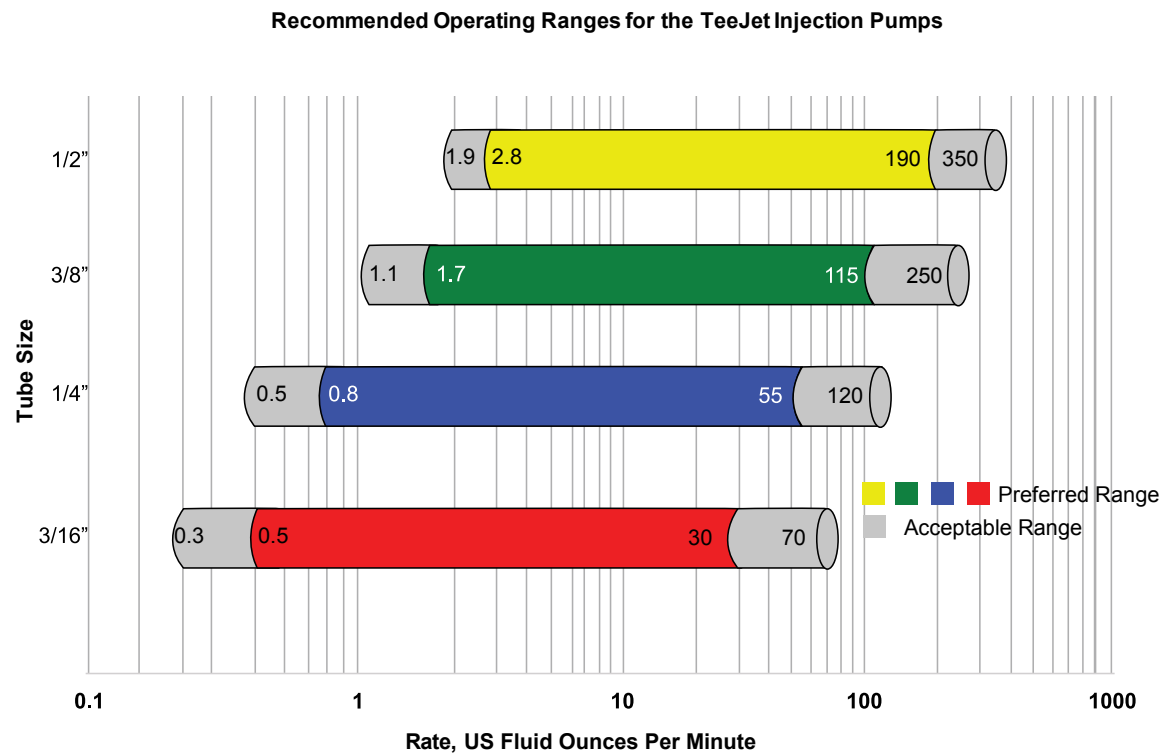
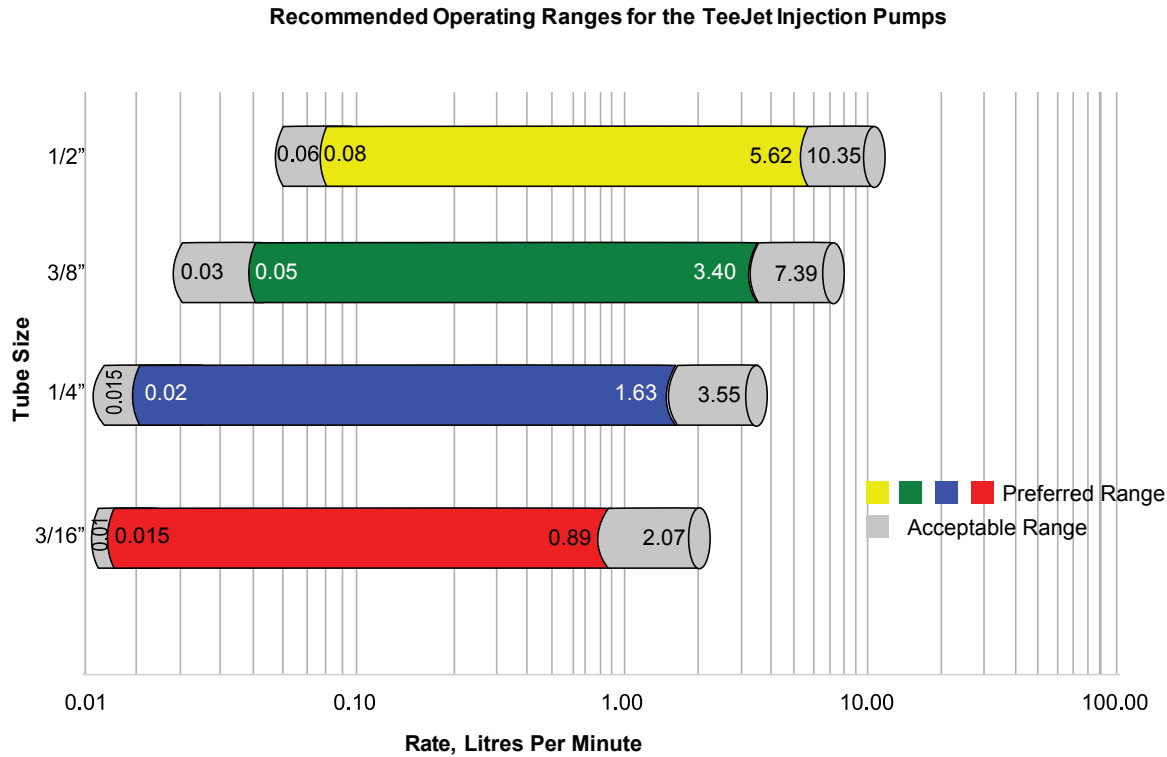

Figure 4: Metric Pump Tube Selection Chart



**NOTE:** It is critical to the accuracy of the pump calibration that back-pressure of at least 10 psi (70 kPa) be applied against the discharge of the pump while calibrating. A diaphragm check valve or similar serves this purpose well. Failure to follow this instruction will result in inaccurate calibration numbers.

The accuracy of product delivery by the MT600 pump is dependent on the pump being accurately calibrated. It is recommended that the pump be calibrated any time the following occurs:

- The first time a pump is installed and used
- Any time a pump tube is changed
- Any time a new chemical is used in the pump
- Any time the operator feels that the pump discharge may not be accurate

If the calibration procedure ever results in a calibration number that does not fall within a range of +/- 10% of the above stated default calibration numbers, the user must stop using the pump immediately and contact their TeeJet Technologies supplier for assistance.

## Pump Tube Installation

To install the pump tube, release the tube retaining strap and lift it up and away from the tube rollers. Coat the tube with Tube Lube (included with tube) THIS IS A REQUIRED STEP. Attach one hose quick disconnect fitting to the left hose connection. Loop the tube over the rollers and down between the tube rollers and the tube strap hinge (there is not enough space between the tube roller assembly and the tube strap hinge to slip the tube in from the front without damaging the tube). Stretch the tube enough to lock the right hose quick disconnect fitting into place. To prevent air leaks in the chemical lines, ensure that the gasket does not fall out or get twisted and that both fittings are tightened. Swivel the tube retaining strap into place and secure with the latch.

# MT600 Injection Pump

## Calibration

Refer to the 026-73 AddFlo User Manual.

Figure 5: Pump Calibration Switch

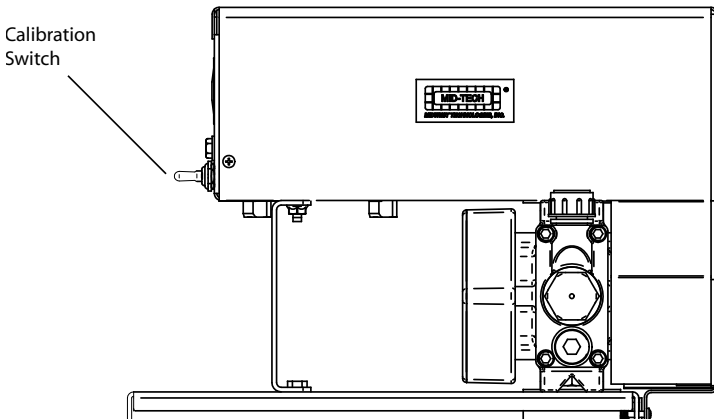
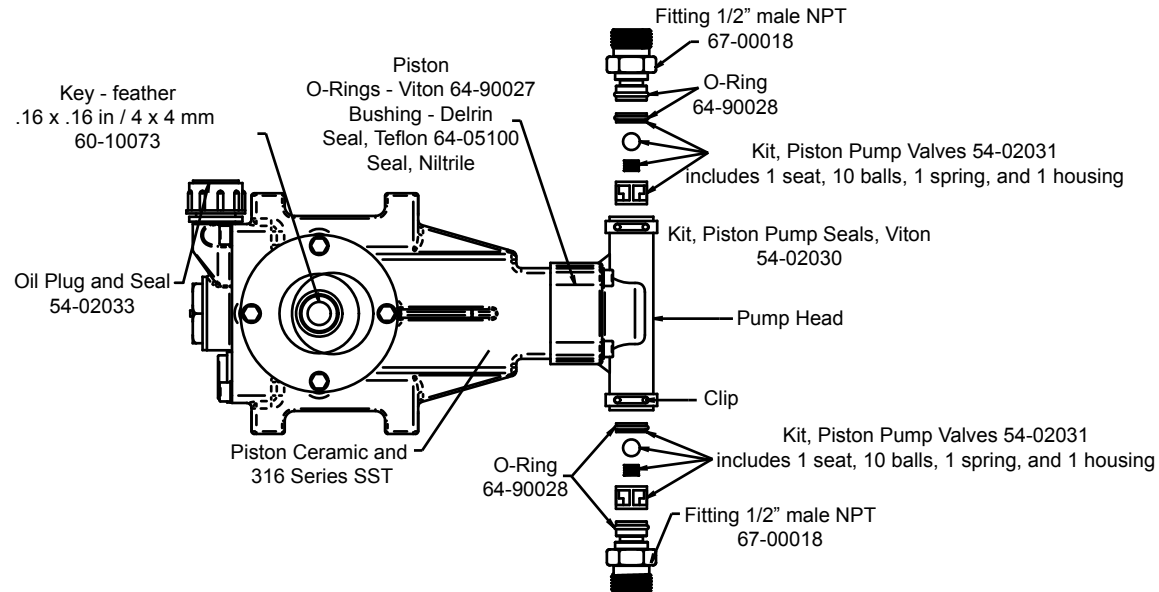

Figure 6: Pump Diagram



## Maintenance

TeeJet Technologies recommends the following maintenance to keep the MT600 injection pump operating at peak efficiency:

### Flushing and Cleaning

Always refer to the Adjuvants manufacturer's directions regarding cleaning and flushing. Check the pump head oil level. The top of the oil level should always be visible somewhere in the viewing window. Do not leave Adjuvants in the pump or application lines overnight. The system should be flushed and cleaned out thoroughly at the end of each day's operation.

### Weekly and Seasonal Pump Maintenance

Check the pump carefully for wear each week during frequent operations. Check for cracking, belt wear, or other signs of material fatigue. If any signs of deterioration are visible, replace the part immediately. Contact your TeeJet dealer for assistance.

Install the ball and seat repair kit (Part number 54-02031) as illustrated in Figure 6. The pump calibration must be checked at the beginning of each season and periodically throughout the year. The pump calibration must be checked any time a pump tube is changed.

Figure 7: System Overview

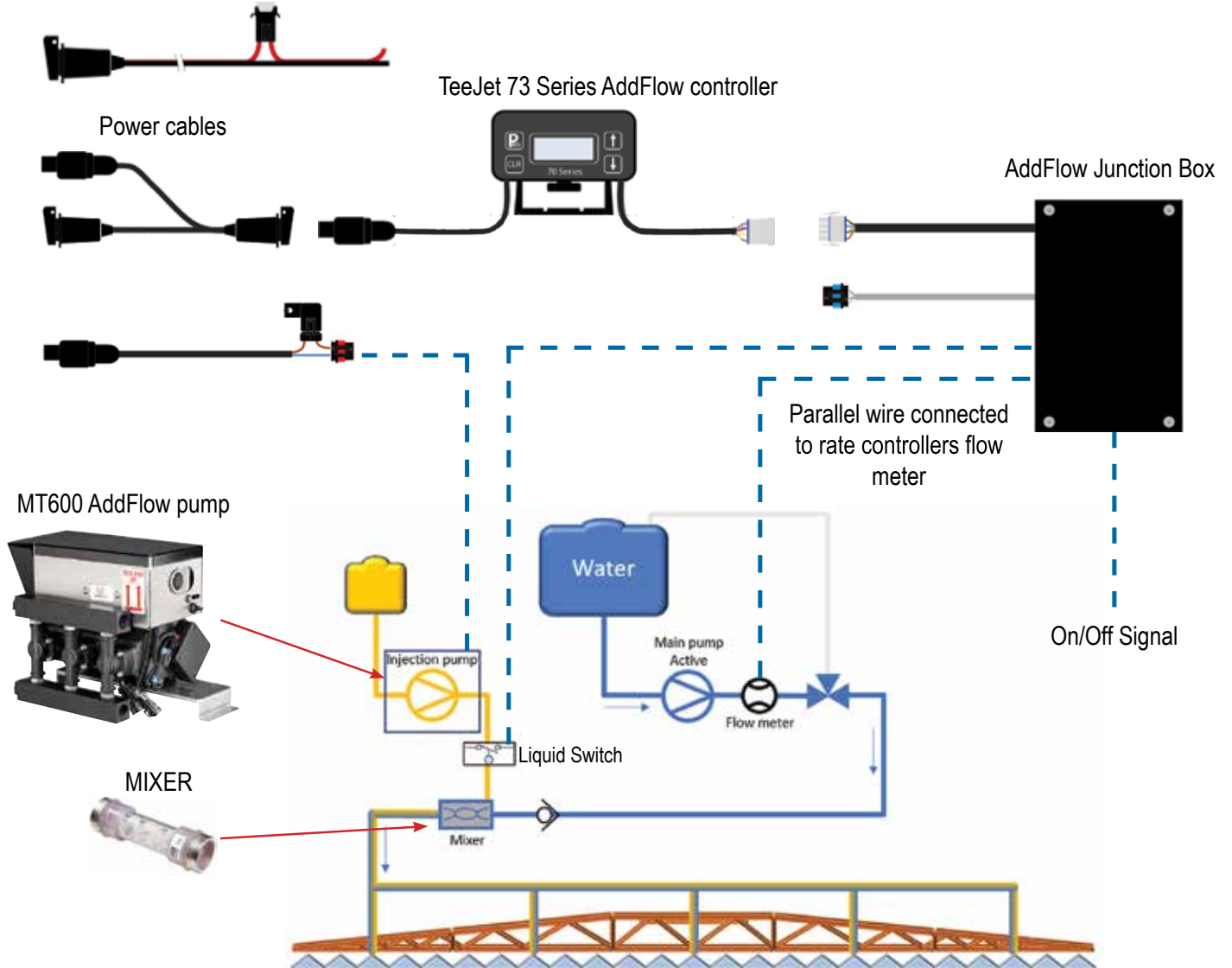

Pump specification	
Electric Power Supply	12 Volts DC < 15 Amps @ Max RPM
Pump Type	Positive Displacement Piston
Dimensions	25.4 mm x 29.1 mm x 40.5 mm
Fluid Output	0.015 to 7 L/min (one to four head)

## Plumbing points of attention

Depending on the sprayer it is recommended to adjust the plumbing to prevent tank mix with Adjuvants to return to the main carrier tank. The moment the spraying stops:

1. The carrier from the main tank (without Adjuvants) has to recirculate back to the tank and
2. The liquid containing Adjuvants stays recirculating in the boom

## Electrical points of attention

In case of retrofitting an existing AddFlow installation, make sure to replace the existing Y-cable with cables 198-332 and 197-259.

In case of connecting an injection logging system logger, please review the corresponding manual of the logger.

# MT600 Injection Pump

Figure 8: Spray Circulation ON Diagram

Circulation, Spray = ON

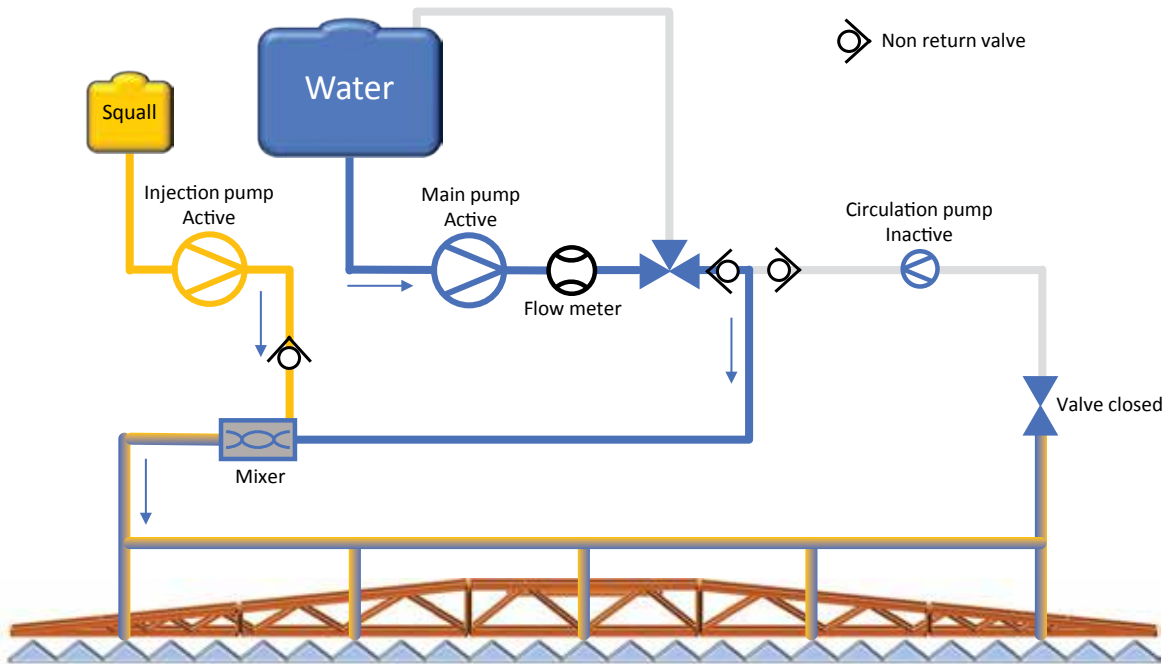

Figure 9: Spray Circulation OFF Diagram

Circulation, Spray = OFF

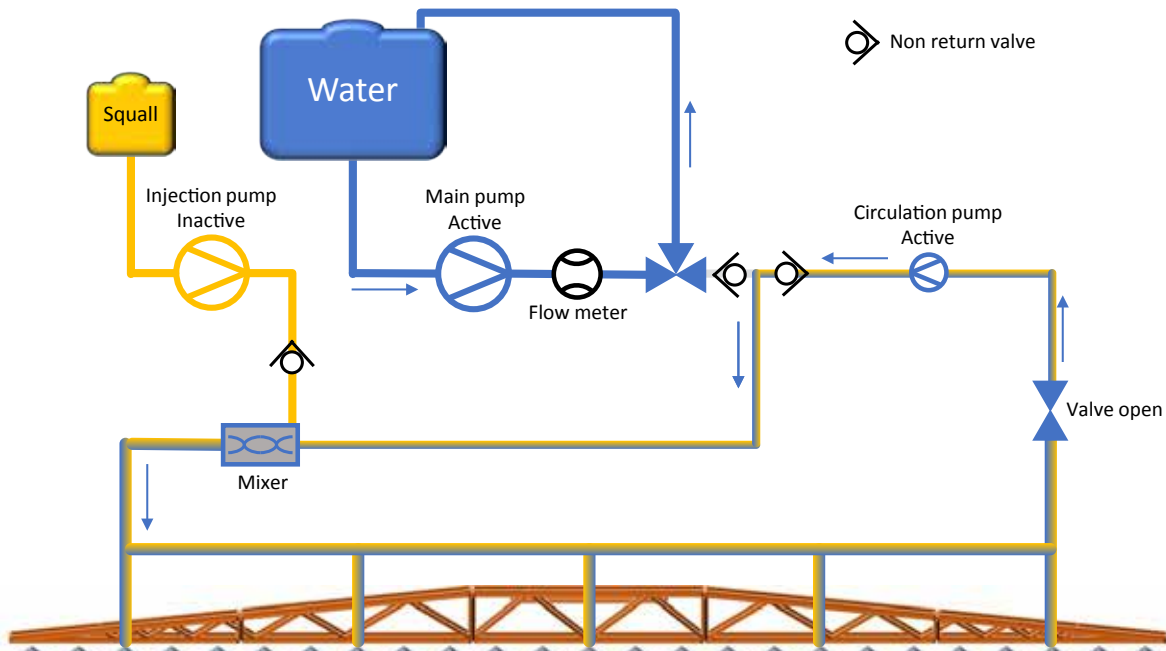

Figure 10: Spray Non-Circulation ON Diagram

Non circulation, Spray = ON

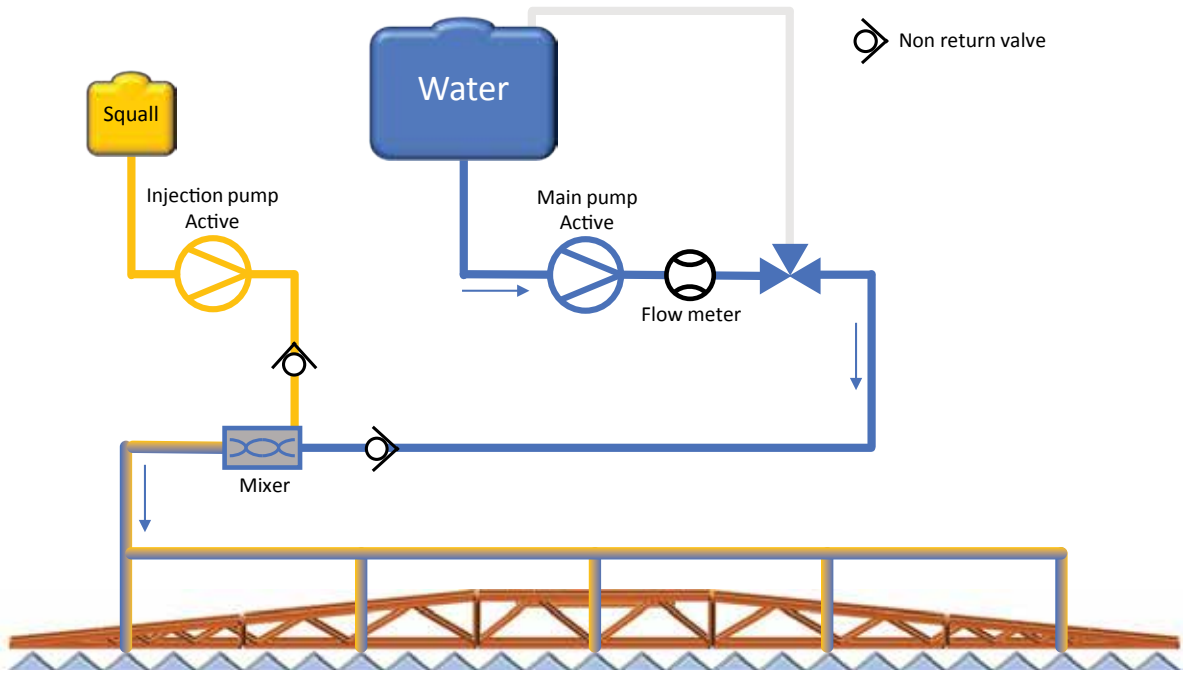
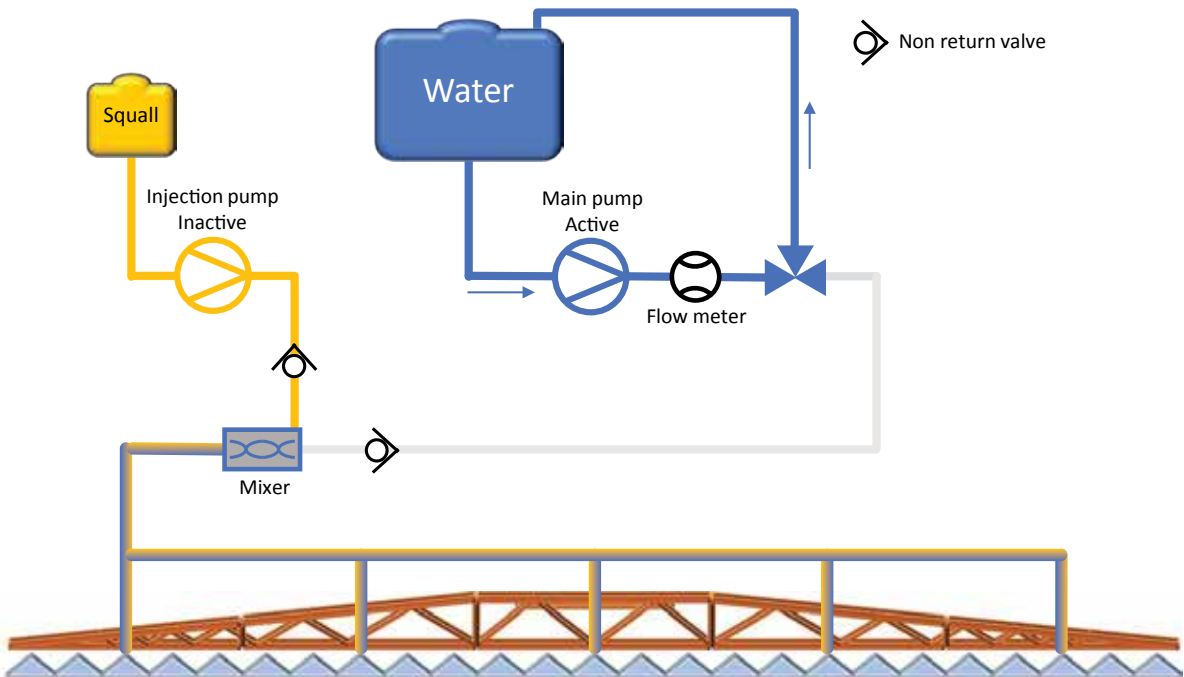

Figure 11: Spray Non-Circulation OFF Diagram

Non circulation, Spray = OFF



# MT600 Injection Pump

## Piston Pump General Specifications

Product Description	
Pump Type:	Positive Displacement Piston Pump
Versatility:	Can inject into pressure side of carrier pump, wide operating range, scalable to fit most applications, modular, serviceable, and compatible with various TeeJet controllers
Performance Characteristics	
Response:	Chemical moves through tube immediately when motor is driven
Motor Speed:	0 to 225 rpm at 12.5 VDC
Pumped Media	
Fluids:	Liquid chemicals only
Electrical	
Power:	30 to 250 watts typical (30 amp fused)
Voltage:	12 volt DC vehicle
Power Connection:	2 pin MetriPak 480 Tower sealed
Physical Properties	
Dimensions:	11.5"H x 10"D x 16"W 29 cm x 25.4 cm x 40.4 cm
Plumbing:	3/4" NPT Manifold
Weight 1 head:	26lbs/11.8kg
Weight 4 heads:	46lbs/20.9 kg
Environmental	
Temperature:	34 degrees F to 140 degrees F 1 degree C to 60 degrees C
Humidity:	Weatherproof (high humidity)
Vibration:	n/a
Dust:	n/a
Pressure	
Max Operating Pressure	100 psi (6.9 bar)

## Calibration Numbers

Pumps:

1. \_\_\_\_\_ 2. \_\_\_\_\_ 3. \_\_\_\_\_ 4. \_\_\_\_\_ 5. \_\_\_\_\_

This space is reserved for recording pump calibration numbers:

## Product Warranty

TeeJet Technologies Illinois LLC warrants to the original purchaser that the product purchased shall be free of defect in material or workmanship. If the product proves to be defective within the warranty period the purchaser must return, freight prepaid, said product to TeeJet Technologies within thirty (30) days after such defect is discovered. Upon inspection and examination by TeeJet Technologies, and at its option, the product shall be repaired or replaced with a new or comparable product. No product will be considered defective if it substantially fulfills the performance specifications. Purchaser shall be responsible for all required maintenance service in accordance with procedures outlined in TeeJet Technologies' product operator manual or service bulletins.

All product(s) replaced or repaired under warranty shall carry the remainder of the warranty left on the original purchase. All out of warranty product(s) serviced for fee or goodwill will have ninety (90) days of warranty. The ninety (90) days shall begin on the date serviced by TeeJet Technologies.

Warranty periods for TeeJet Technologies products shall be:

- TeeJet and Mid-Tech Control Consoles - 2 1/2 years
- TeeJet and Mid-Tech Switch boxes - 2 1/2 years (3, 5, 9 booms)
- All other products - 12 months unless otherwise noted

## Warranty Limitations and Exclusions

TeeJet Technologies will have no warranty obligations hereunder if the product is subjected to abuse, misuse, improper or abnormal usage, acts of God, faulty installation, or improper maintenance as outlined in TeeJet Technologies' product operator manual or service bulletins. Consumable items (items that are used during normal operations) such as light bulbs, batteries, etc., and expendable items (items that wear out in normal use) such as injection pump tubes, flow meter bearings, etc., will not be covered by warranty. For products that come in direct contact with chemical, the specific recommendations contained in TeeJet Technologies product bulletins must be adhered to, or this warranty is void. Any repairs or alternations, other than those provided by TeeJet Technologies and/or its authorized representatives, will void the warranty. TeeJet Technologies neither assumes nor authorizes anyone to assume for it any other obligation or liability in connection with said product.

## Disclaimer of Unstated Warranty

The warranty printed above is the only warranty applicable to this purchase. TeeJet Technologies' warranty cannot be modified by any person or entity, including without limitation, any distributor or retailer of TeeJet Technologies. All other warranties, express or implied, including but not limited to, the implied warranties of merchantability and fitness for a particular purpose, are disclaimed.

# MT600 INJECTION PUMP

U S E R M A N U A L

---



A Subsidiary of  *Spraying Systems Co.*

[www.teejet.com](http://www.teejet.com)

98-05357 ENUS-LT R0 English-US  
© TeeJet Technologies 2022