

BOOMPILOT[®]

INSTALLATION MANUAL

Automatic boom section control installation manual
for use with Berthoud DP Tronic w/Matrix[®] Pro



TeeJet[®]
TECHNOLOGIES

BoomPilot[®]

A Subsidiary of  Spraying Systems Co.[®]

Copyrights

© 2013 TeeJet Technologies. All rights reserved. No part of this document or the computer programs described in it may be reproduced, copied, photocopied, translated, or reduced in any form or by any means, electronic or machine readable, recording or otherwise, without prior written consent from TeeJet Technologies.

Trademarks

Unless otherwise noted, all other brand or product names are trademarks or registered trademarks of their respective companies or organizations.

Limitation of liability

TEEJET TECHNOLOGIES PROVIDES THIS MATERIAL "AS IS" WITHOUT WARRANTY OF ANY KIND, EITHER EXPRESSED OR IMPLIED. NO COPYRIGHT LIABILITY OR PATENT IS ASSUMED. IN NO EVENT SHALL TEEJET TECHNOLOGIES BE LIABLE FOR ANY LOSS OF BUSINESS, LOSS OF PROFIT, LOSS OF USE OR DATA, INTERRUPTION OF BUSINESS, OR FOR INDIRECT, SPECIAL, INCIDENTAL, OR CONSEQUENTIAL DAMAGES OF ANY KIND, EVEN IF TEEJET TECHNOLOGIES HAS BEEN ADVISED OF SUCH DAMAGES ARISING FROM TEEJET TECHNOLOGIES SOFTWARE.



Safety information

TeeJet Technologies is not responsible for damage or physical harm caused by failure to adhere to the following safety requirements.

As the operator of the vehicle, you are responsible for its safe operation.

The BoomPilot is not designed to replace the vehicle's operator.

Do not leave a vehicle while the BoomPilot is engaged.

Be sure that the area around the vehicle is clear of people and obstacles before and during engagement.

The BoomPilot is designed to support and improve efficiency while working in the field. The driver has full responsibility for the quality and work related results.

Disengage BoomPilot before operating on public roads or when not in use to prevent loss of vehicle control.

Table of contents



REQUIRED COMPONENTS	2
PRINCIPLE OF OPERATION	5
INSTALLATION	5
1. LOCATE THE CONNECTION POINT FOR THE SDM HARNESS	5
2. MOUNT & CONNECT SDM.....	5
3. DISCONNECT & RECONNECT HARNESSES & CABLES	6
4. CONNECT POWER/CAN/DATA CABLE TO BOOMPILOT HARNESS	7
5. INSTALLING THE INTERFACE	7
Factory installed ABS Berthoud interface, diagrams and modifications.	8
Battery Cable (Option)	13
Valves connection.....	13
Driving wires connection to relay box	14
Valves connections to relay box.....	14
6. RECOMMENDED ELECTRONICS INSTALLATION	15
7. COMPLETE ELECTRONIC INSTALLATION	15
SYSTEM CHECK	15
Check AUTOMATIC mode:	15
<i>Berthoud DP Tronic:</i>	15
<i>Matrix Pro:</i>	15
Check MANUAL mode:.....	15
<i>Berthoud DP Tronic:</i>	15
<i>Matrix Pro:</i>	15

REQUIRED COMPONENTS

Unpack the installation kit and identify the required parts for your installation.

Item	Part Number	Description	Quantity
A	90-xxxx*	Matrix Pro guidance controller kit	1
B	45-05845	Power/CAN/data cable	1
C	198-413	BoomPilot harness (CANBUS & Power).....	1
D	48-XXXXX	Power cable with 3P COBO connector	1
E	990-888*	BoomPilot cable, 990-888 (Max. 15 Sections + Master for New Safi or Pneumatic Valves)	1
E	990-889*	BoomPilot cable, 990-889 (Max. 15 Sections + Master for Old Safi or ARAG Valves).....	1
F	78-05072	BoomPilot section driver module (SDM).....	1
G	020-045	Installation manual, Berthoud DP Tronic.....	1
H	98-05243	Matrix Pro BoomPilot setup guide	1

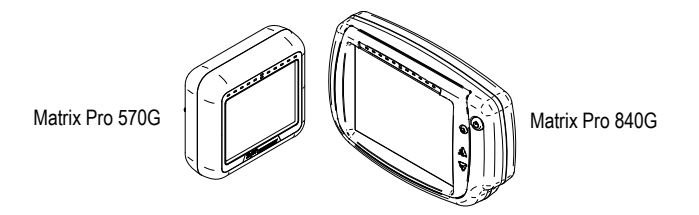
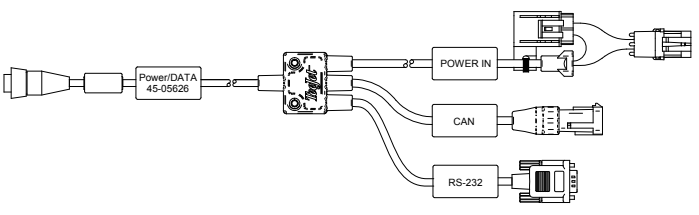
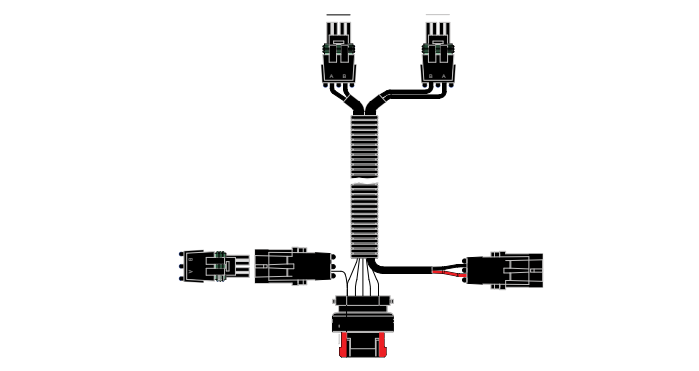
*Part number is dependent on kit contents

Item	Part #	Description	Illustration
A	Part number is dependent on kit contents	Matrix Pro guidance controller kit	 <p>Matrix Pro 570G Matrix Pro 840G</p>
B	45-05845	Power/CAN/data cable	 <p>Power/DATA 45-05826 POWER IN CAN RS-232</p>
C	198-413	BoomPilot harness (CANBUS & Power)	
D	48-XXXXX	Power cable with 3P COBO connector	
E	990-888*	BoomPilot cable, 990-888 (Max. 15 Sections + Master for New Safi or Pneumatic Valves)	

Item	Part #	Description	Illustration
E	990-889*	BoomPilot cable, 990-889 (Max. 15 Sections + Master for Old Safi or ARAG Valves)	
F	78-05072	BoomPilot section driver module (SDM)	
G	020-045	Installation manual, Berthoud DP Tronic	
H	98-05243	Matrix Pro BoomPilot setup guide	

Figure 1: System diagram



PRINCIPLE OF OPERATION

The BoomPilot system controls the sections valves according to the GPS position. The GPS makes it possible to avoid overlaps or skips.

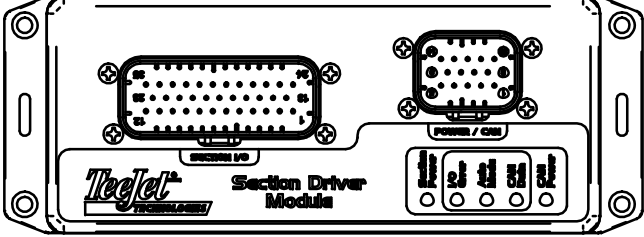
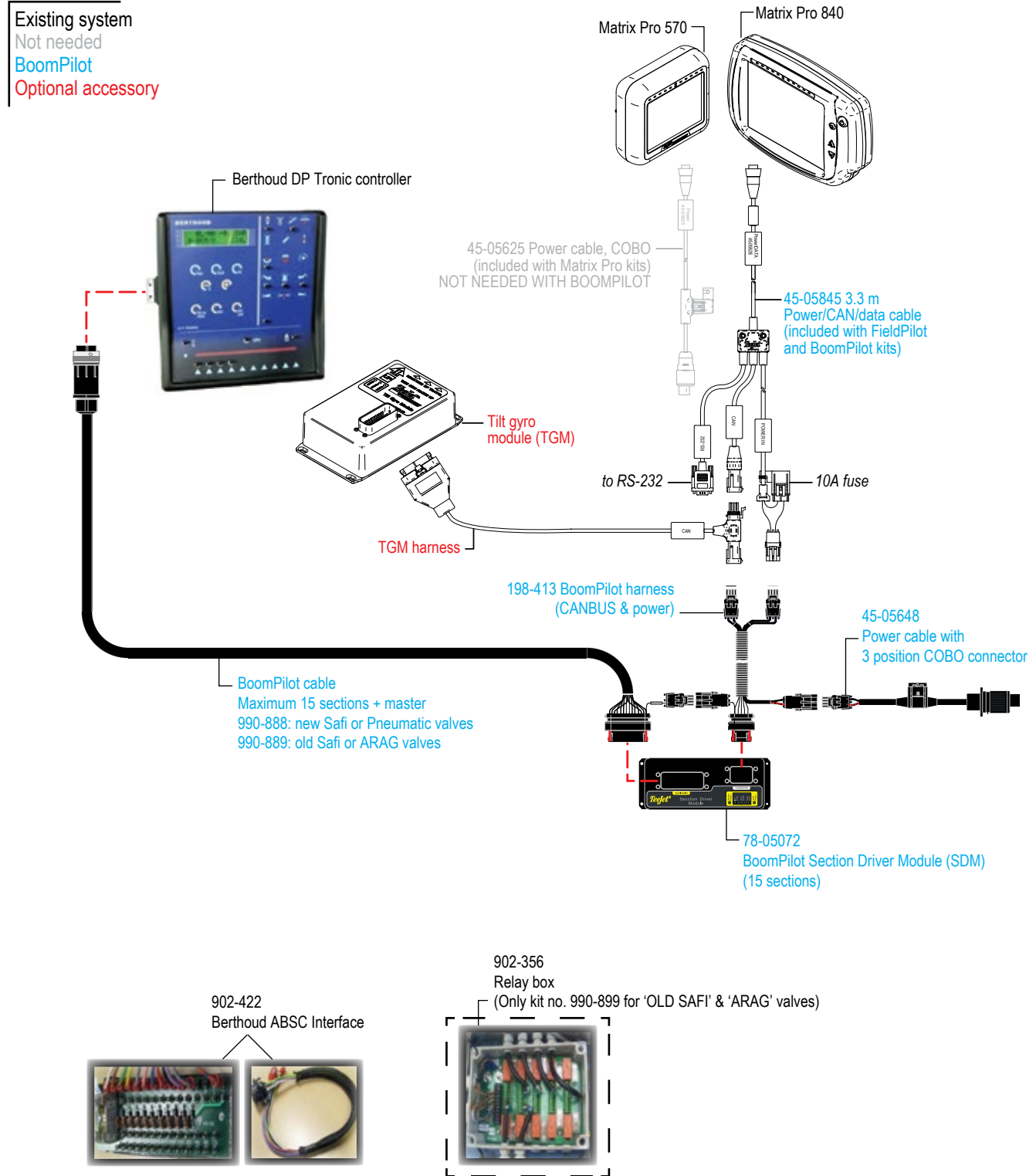
The Section Driver Module (SDM) is designed for switching active high when spraying. This means that a 12V signal is issued to control the corresponding section valve.

The SDM is connected in parallel with the controller section switches.

The BoomPilot controls the section valves in automatic mode, and the controller section switches should be set to off unless the operator wants to override the auto mode and thus force spraying.

The BoomPilot monitors the controller section switches that controls the valves in manual mode. The the Master switch can be used both in automatic mode as well as in manual mode.

Figure 2: Principle of operation

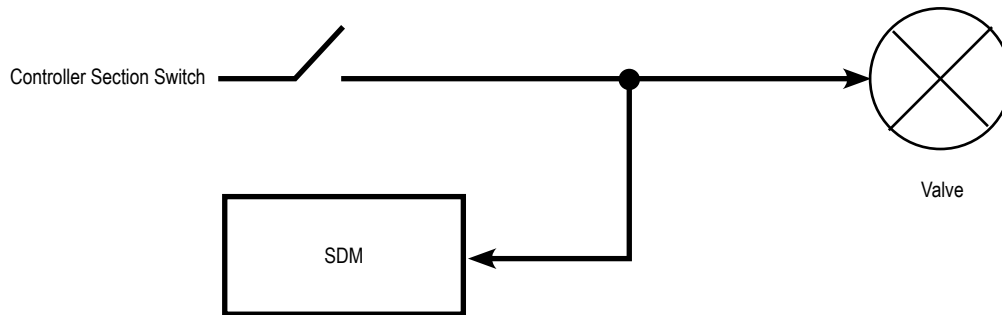

INSTALLATION



If there are questions concerning the installation of the BoomPilot system on this vehicle, or due to the changes in component specifications the parts supplied in the kit are not exactly as presented in this document, please contact your dealer or TeeJet Customer service representative for clarification before installation. TeeJet Technologies is not responsible for misuse or incorrect installation of the system.

NOTE: All references to left and right are stated as if the user is seated in the driver's seat.

NOTE: BE VERY CAREFUL TO ABSOLUTELY SECURE ALL CABLES AND HOSES SO THAT THEY DON'T INTERFERE WITH THE MANY MOVING PARTS OF THE MACHINE!

1. LOCATE THE CONNECTION POINT FOR THE SDM HARNESS

Locate the existing system's flow control harness on the right side of the cab under the control panel inside the black cowling as it routes up to the back of the Berthoud DP Tronic console.

2. MOUNT & CONNECT SDM

1. Mount SDM (E) as shown where LED's can be seen for troubleshooting.
2. Connect SDM (E) to BoomPilot Harness (C).

Figure 3: Connect SDM

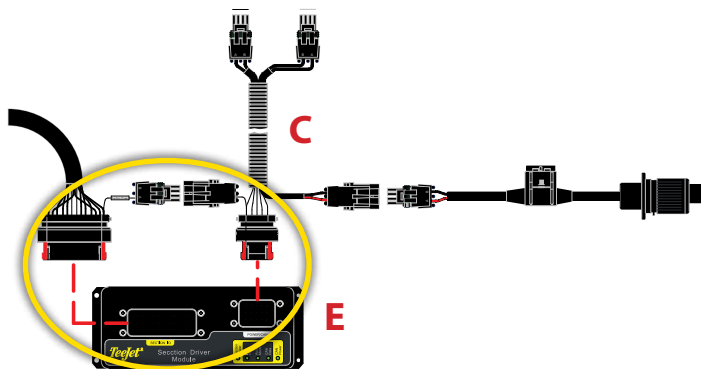

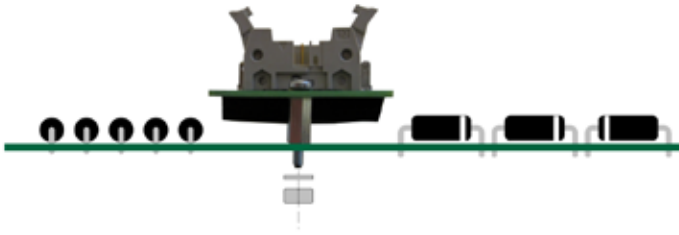

4. Install the interface in the box by fixing it at a corner of the main board as shown on the picture.

Note: Be sure that no contact is possible between the two boards

5. Connection of the wires depend on the sprayer type (See the wiring diagrams starting page 8)
6. Connect the cable from the external connector to the board, if not yet done, in the middle row.
7. Connect the interface to the CPU board with the flat cable.

8. Disconnect the wires from the “Carte Pulvé” board and connect them to the interface.
9. Connect the wires from the interface to the “Carte Pulvé” board.

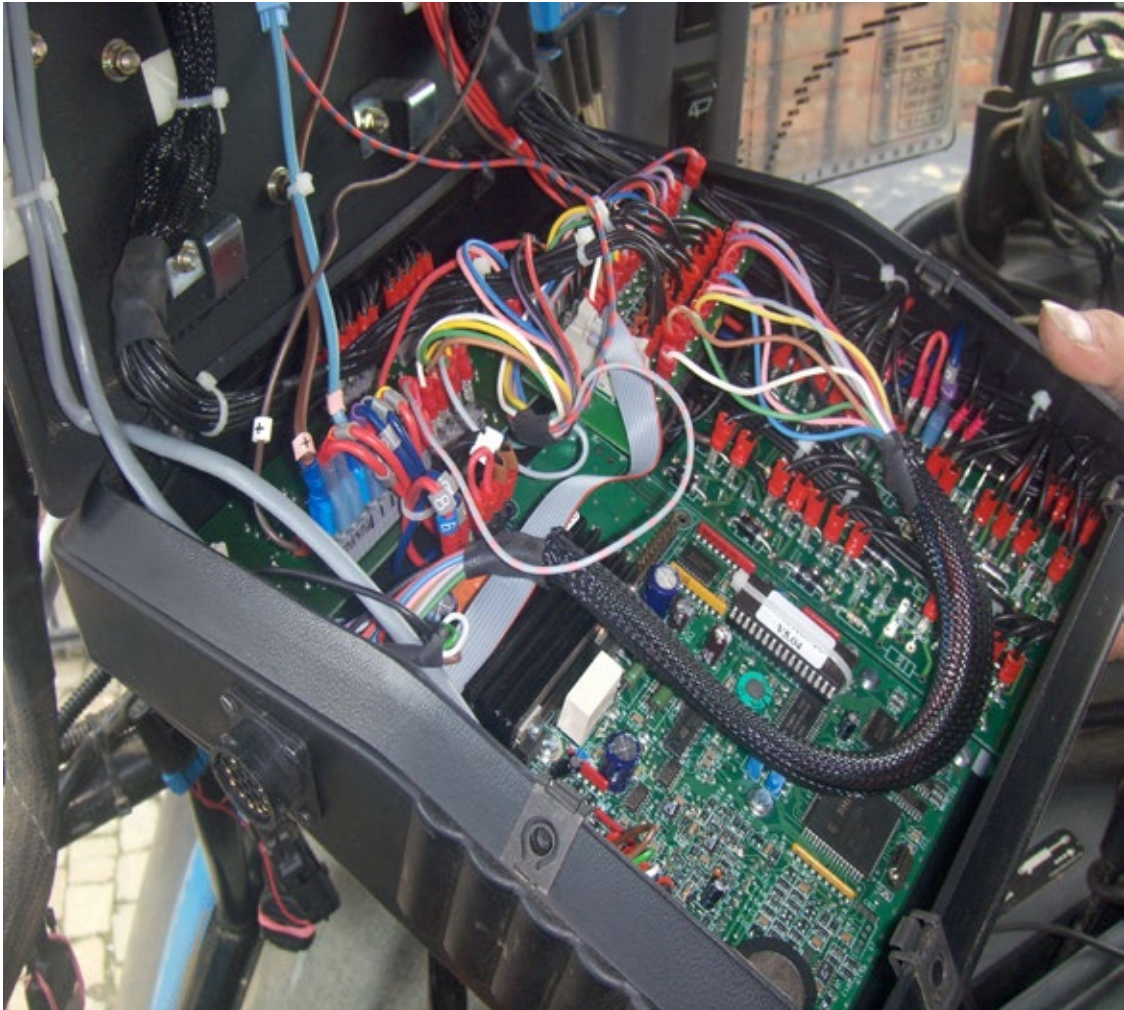

The above picture shows the ABSC interface built into a Trailed Sprayer without joystick (CASE-1, page 9).

Factory installed ABSC Berthoud interface, diagrams and modifications.

Even if the Berthoud ABSC interface is already installed, please follow carefully the modifications and diagrams.

WARNING: If the below modifications are not realized, there is a big risk that the ABSC interface will burn at the first run

Diagram Description:

4. DISCONNECT & RECONNECT HARNESSSES & CABLES

The BoomPilot SDM harness (C) tees into the existing system's connection between the Berthoud DP Tronic rate controller and flow control harness.

1. Disconnect existing connection at the back of the Berthoud DP Tronic console.
2. Connect BoomPilot harness (C) to Berthoud DP Tronic console.
3. Connect BoomPilot harness (C) to existing Berthoud DP Tronic flow control harness.

Figure 5: Disconnect existing connection



Figure 6: BoomPilot harness to flow control harness



BoomPilot harness to controller



5. CONNECT POWER/CAN/DATA CABLE TO BOOMPILOT HARNESS

Connect Power/CAN/data cable (B) to BoomPilot harness (C).

Figure 7: Connect power/CAN/data cable to BoomPilot harness

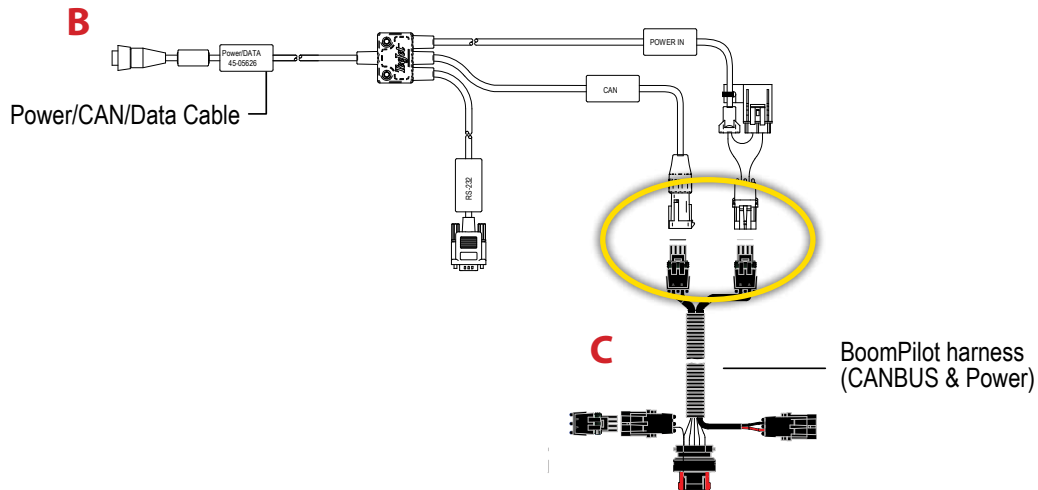

Position	Description
1	DP Tronic board, 'CARTE DP TRONIC'
2	Sprayer board, 'CARTE PULVE'
3	Flex cable, from ABSC interface to DP Tronic board
4	Berthoud ABSC interface
5	Cable from ABSC interface to the 'Carte Pulve' board (Part of PN 902-422)

Position	Description
6	Cable from ABSC interface to the SCM module, 19P connector (Part of PN 902-422)
7	Existing cable from switch's or joystick

CASE-1: Trailed Sprayer without Joystick

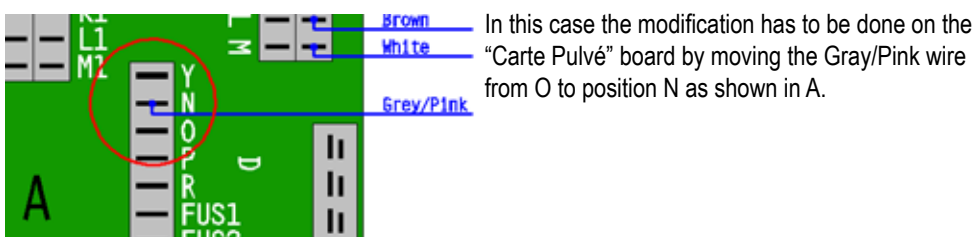
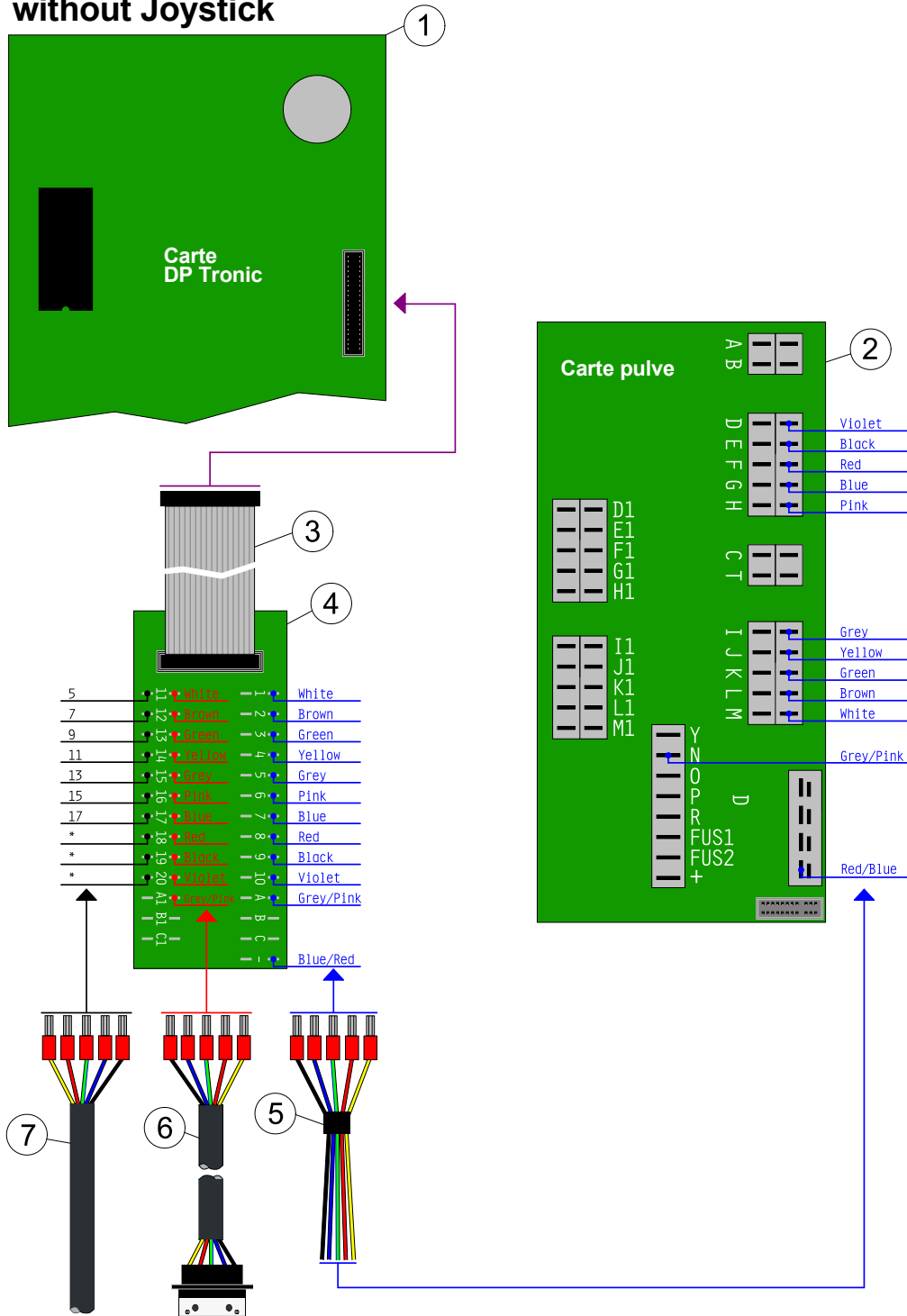

CASE-2: BOXER DPT with Joystick

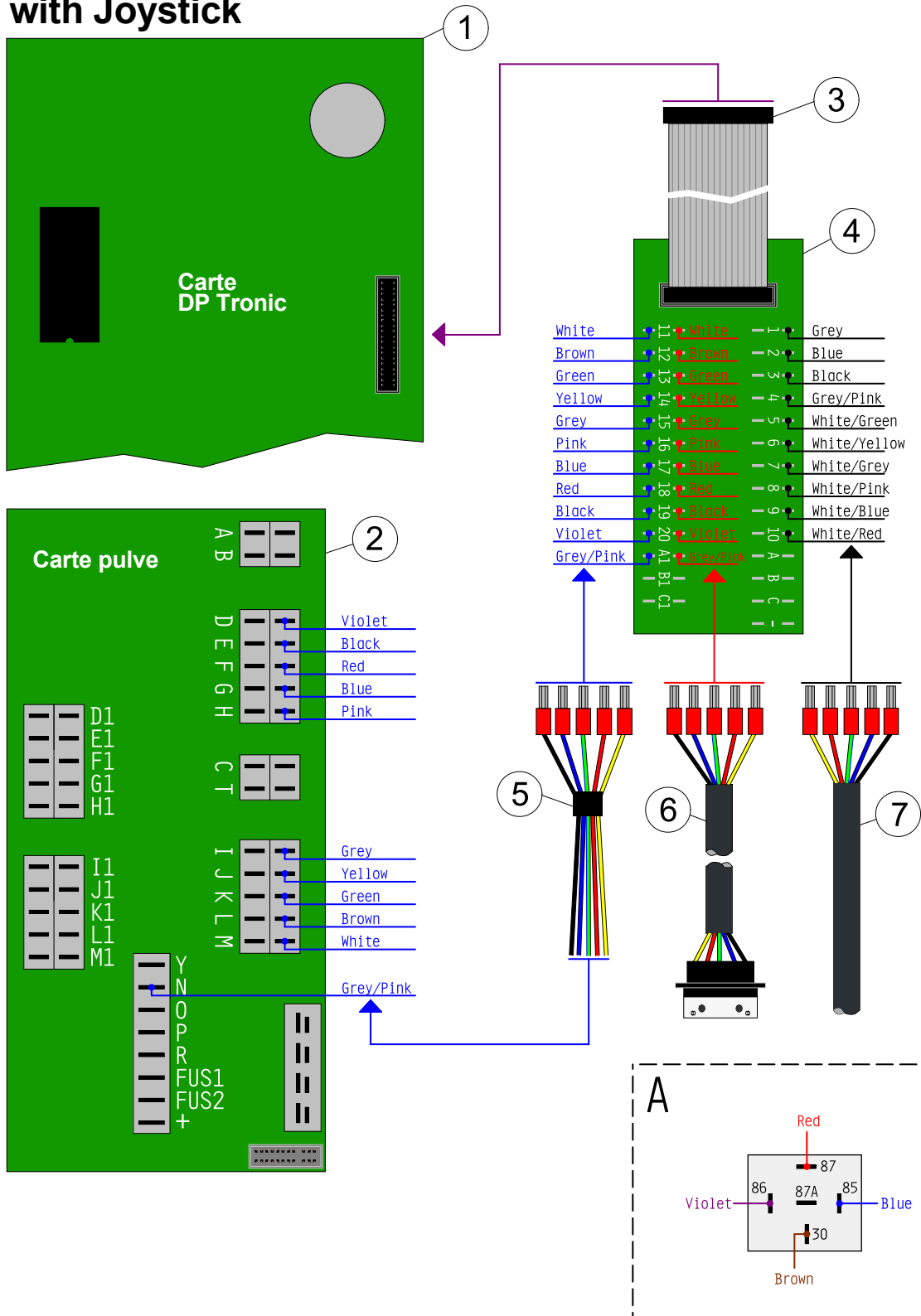

In this case, the relay wiring should be modified to match the cabling shown in A. That means that the RED and the BROWN wires should be reverted, so that the RED is connected to position 87 of the relay and the BROWN connected to position 30 of the relay.

The GRAY/PINK wire should be removed from the relay and be connected to the "Carte Pulvé" on position N.

CASE-3: BOXER GST with Joystick

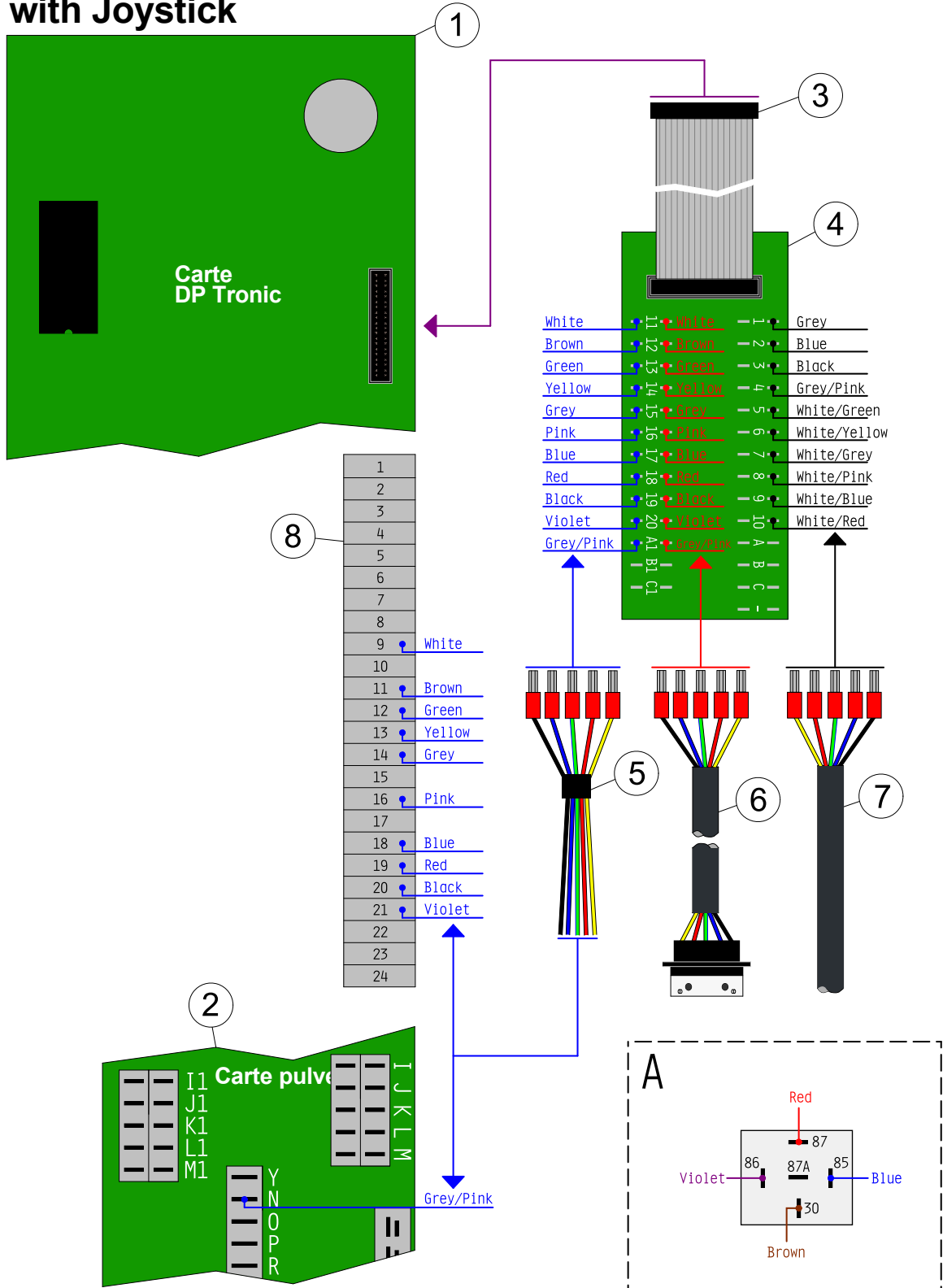

In this case, the relay wiring should be modified to match the cabling shown in A. That means that the RED and the BROWN wires should be reverted, so that the RED is connected to position 87 of the relay and the BROWN connected to position 30 of the relay.

The GRAY/PINK wire should be removed from the relay and be connected to the "Carte Pulvé" on position N.

CASE-4: Trailed Sprayer with Joystick

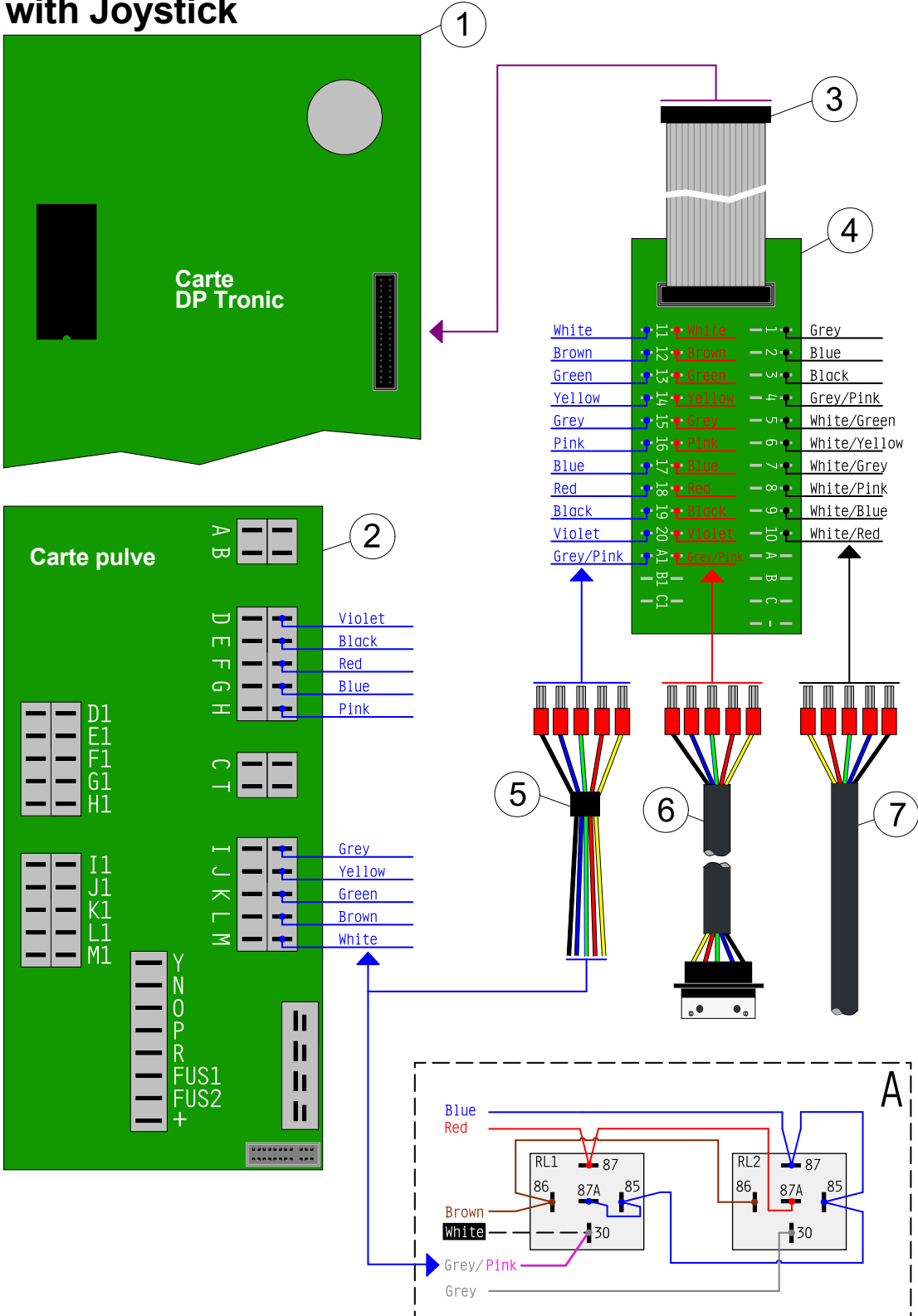

In this case, the relay wiring should be modified to match the cabling shown in A. The GRAY/PINK wire should be removed from the second relay (RL2, position 30 with GRAY wire) and be moved to the first relay (RL1, position 30 with WHITE wire).

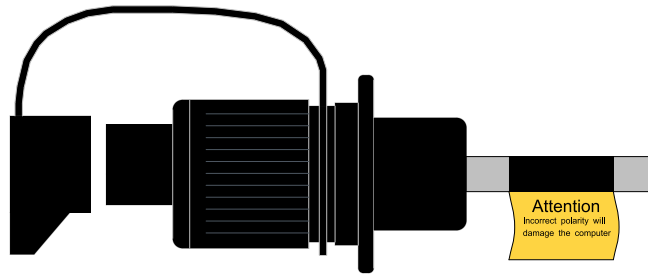
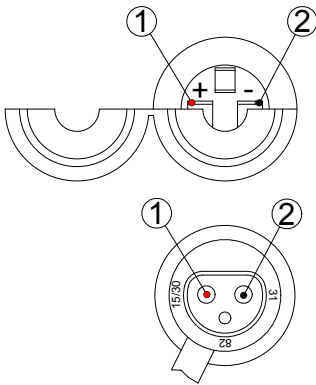

Position	Description
1	+12V (15/30)
2	Ground (31)

Warning: When connecting the system to 12V power it's very important that the polarity is correct, if not the system will be damaged.

Battery Cable (Option)

The power supply must be strong enough to operate the Section and Master valves. The total current will depend on the used valve type. If a power connector (Socket) isn't available in the tractor cabin, a optional battery cable can be used (PN 96ET14).



Valves connection

Berthoud sprayers with New Safi or pneumatic valves - No particular connection has to be done. Original cabling is ok.

Berthoud sprayers with Old Safi or Arag valves -Relay box installation

Take out the blue cover above the boom



Fix the relay box to the frame

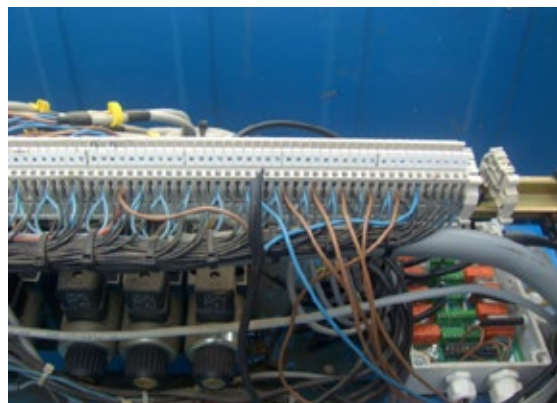

Driving wires connection to relay box

Connect loose wires to the connection bloc. Below a informative table but verify that the respective connections are giving out 12 V when section is ON.

Name	S1	S2	S3	S4	S5	S6	S7	S8	GND	12V
Pin	8	11	14	17	20	23	27	30	6	37

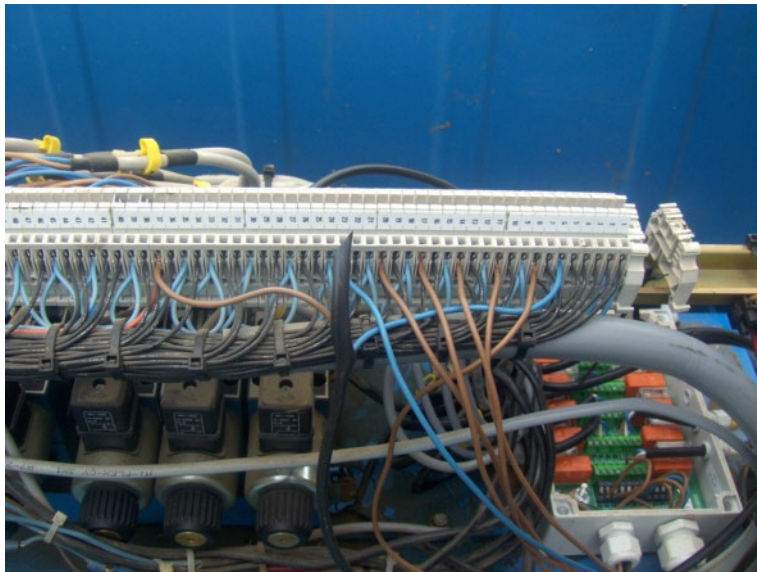

Valves connections to relay box

Disconnect the valves from the connection bloc and connect them into the relay box.

	Wire Color	Connection	Function
SAFI	Brown	NH	12 V for closing
	White	NL	12 V for opening
	Blue	GND	Permanent Ground
ARAG	Brown	NH	12 V for closing
	Blue	NL	12 V for opening

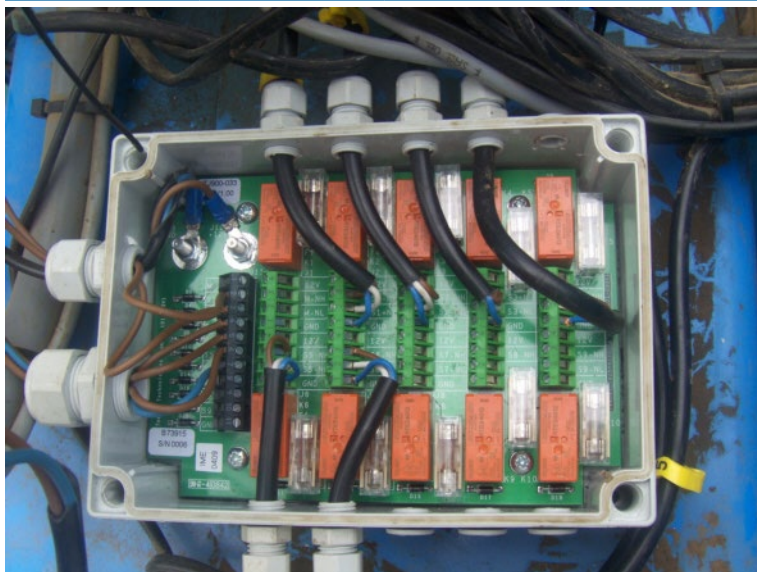

6. RECOMMENDED ELECTRONICS INSTALLATION

The control console can be mounted to the operator's preference. The GPS antenna should be mounted in the center on top of the cab on a metal surface of at least 10 cm square.

Figure 8: Recommended electronics installation

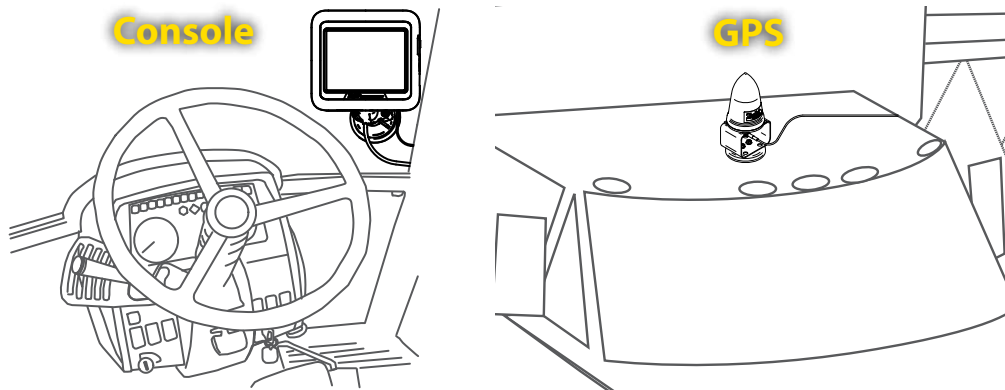

7. COMPLETE ELECTRONIC INSTALLATION

Refer to the Matrix Pro BoomPilot Setup Guide for further instructions on setting up and using your Matrix Pro for ABSC.

If not using a Matrix Pro, please refer to the owner's manual supplied with the guidance system to complete the electronic installation and setup.

SYSTEM CHECK

After connecting the power connector, it is time to make a system check. To check the system, it is necessary to have full GPS signal. To obtain full GPS signal, the vehicle must be placed outside.

Check AUTOMATIC mode:

Berthoud DP Tronic:

Section switches should be in the OFF position when working in Automatic mode. The Master switch will control the sprayer and should be ON to enable automatic switching of the sections.

Matrix Pro:

- Turn on the Matrix Pro console
- Encode the number of sections and the width of each (Refer to the Matrix Pro user manual)
- Wait for GPS signal
- Set the BoomPilot mode to AUTOMATIC
◀ Status Bar Icon will change to green ▲
- Drive forward (> 2 km/h)
- Observe that all valves open
- Check that the valves close when the Master switch is set to OFF

Check MANUAL mode:

Berthoud DP Tronic:

- Set the section switches to ON
- Set the Master switch to ON

Matrix Pro:

- Set the BoomPilot mode to MANUAL
◀ Status Bar Icon will change to red ▲
- Check in the 'Vehicle View Screen' (Matrix Pro) that the section icons turn off and on according to the valve/switch status
- Observe that all valves are open

Figure 9: Automatic to all booms on mode



BOOMPILOT[®]

USER MANUAL

A series of equipment-specific installation kits have been developed to work in conjunction with your automated boom section control system. This kit contains the necessary components and instructions to install ABSC on a Berthoud DP Tronic w/Matrix[®] Pro. Please review this manual thoroughly before beginning the installation process.

BoomPilot[®]



TeeJet Aabybro
Mølhavevej 2
DK 9440 Aabybro
Danmark
www.teejet.com

A Subsidiary of  **Spraying Systems Co.[®]**

020-045-UK R2 EN English
© TeeJet Technologies 2013